

TUNING S.U. CARBURETTORS

INCLUDING FULL NEEDLE CHARTS



CARS
AND CAR CONVERSIONS

SPEED
SPORT
MOTORBOOKS

97L

TUNING



CARBURETTORS

INCLUDING FULL NEEDLE CHARTS

CONTENTS

SECTION 1

A four-point guide to getting the best performance and economy from your S.U.(s). Page 6

SECTION 2

Servicing, dismantling and reassembly. Page 12

SECTION 3

Tuning twin carburettors. Page 24

APPENDIX 1

Carburettor specifications Page 31

APPENDIX 2

Needle charts Page 38

SPEED SPORT MOTOBOOKS

THE PERFORMANCE PAPERBACKS



INTRODUCTION TO TUNING

Martyn Watkins

The first in a series of tuning companions designed to give the novice a complete guide to all aspects of the tuning and modification of the production car. This book covers the theory of how a car works and the methods by which it can be made to work more efficiently.

37½p (7/6)

TUNING COMPANION VOL. 2. ENGINES AND TRANSMISSIONS

Martyn Watkins

Following on from the preliminaries of 'Introduction to Tuning' this second book explains the tuning possibilities for cylinder heads, valves, camshafts, carburettors, cranks and transmissions.

50p (10/-)



Tuning Companion Vol. 3— Suspension and brakes by Martyn Watkins

This book is the third and final volume in the series of Tuning Companions by Martyn Watkins. It enlarges on the details given in volume 1 and covers suspension and its modifications, wheels and tyres, brakes, bodywork modification instruments and lights.

50p (10/-)



The Speed Sport Motobooks series is designed to present the performance and motor sport enthusiast with inexpensive guides to their particular enthusiasm. The books are constantly re-edited to keep up with modern trends and innovations, and are written by accredited experts backed by the editorial team from the monthly magazine Cars and Car Conversions. The list is always growing and some of the more popular titles are listed here. Should you require an up to date list, please send a stamped addressed envelope to us at the address below.

MARQUE TUNING GUIDES

TUNING A MINI by Clive Trickey	90p	<input type="checkbox"/>
MORE MINI TUNING by Clive Trickey	70p	<input type="checkbox"/>
TUNING STANDARD-TRIUMPHS up to 1300 c.c.	50p	<input type="checkbox"/>
TUNING STANDARD TRIUMPHS over 1300cc	£1.60	<input type="checkbox"/>
TUNING VOLKSWAGENS by Peter Noed	90p	<input type="checkbox"/>
TUNING ESCORTS AND CAPRIS by David Vizard	80p	<input type="checkbox"/>
TUNING BMC SPORTS CARS by Mike Gerton	90p	<input type="checkbox"/>
TUNING ANGLIAS & CORTINAS	60p	<input type="checkbox"/>
TUNING TWIN CAM FOROS	90p	<input type="checkbox"/>
TUNING IMPRS by Willy Griffiths	50p	<input type="checkbox"/>
TUNING VIVAS by Blydenstein and Coburn	50p	<input type="checkbox"/>
TUNING V8 ENGINES by David Vizard	£1.50	<input type="checkbox"/>

CARBURETTOR MAINTENANCE AND TUNING

S.U. CARBURETTORS	40p	<input type="checkbox"/>
WEBER CARBURETTORS by John Pessini.	70p	<input type="checkbox"/>
STROMBERG CARBURETTORS	40p	<input type="checkbox"/>

SPORT HANDBOOKS

HOW TO START RALLYING by R. Hudson-Evans	90p	<input type="checkbox"/>
HOW TO START MOTOR RACING by Wally Hall	60p	<input type="checkbox"/>
HOW TO START AUTOCROSS AND RALLYCROSS	70p	<input type="checkbox"/>

AUTOMOBILE ENGINEERING

INTRODUCTION TO TUNING	37½p	<input type="checkbox"/>
ENGINES & TRANSMISSIONS	50p	<input type="checkbox"/>
SUSPENSION & BRAKES	50p	<input type="checkbox"/>
AUTO ELECTRICS by David Westgate	90p	<input type="checkbox"/>
MODIFYING PRODUCTION CYLINDER HEADS	40p	<input type="checkbox"/>
RACING ENGINE PREPARATION by Clive Trickey	80p	<input type="checkbox"/>
CAR CUSTOMISING by Paul Cockburn	90p	<input type="checkbox"/>

These and other advertised Speedsport Motobooks should be obtainable from all good booksellers. If you have any difficulty please tick the appropriate box and send your remittance for the purchase price plus 7½p for postage and packing direct to us.

SPEEDSPORT MOTOBOKS

ACORN HOUSE, VICTORIA ROAD, ACTON, LONDON W3.

**FIRST IMPRESSION APRIL 1968
SECOND IMPRESSION JULY 1970**

ACKNOWLEDGEMENT

We should like to acknowledge the invaluable assistance given by the S.U. Carburetter Company in letting us reproduce so much of their literature. In particular we thank them for the information on their carburetter specifications and needles — which will be of so much help to readers of this book.

We hope that this book will serve as a trusty guide to millions of motorists running cars with S.U. carburetters.

IMPORTANT

The tuning procedure described in this publication does not apply to vehicles sold in the U.S.A. after October, 1968, and which are made to satisfy the U.S.A. statutory regulations regarding exhaust emission. These carburetters must not be dismantled or the settings altered without reference to the relevant manufacturers' servicing instructions.

Printed and Published by

SPEED AND SPORTS PUBLICATIONS LTD

Acorn House, Victoria Road, Acton, London W.3.

© Copyright 1968 by Speed and Sports Publications Ltd. All rights reserved

SECTION I

SINCE so many people have been writing in asking what needles, and jets to use in such and such car or induction set-up, and in view of the fact that it is impossible in most cases to give a clear cut answer we have attempted to explain just how one can obtain the correct answers.

First let us consider why it is usually impossible to give a clear-cut answer to reader's carburation problems. As explained in the recent Mini Tuning series and book, even small variations in engine specification can radically alter the carburation requirements of an engine. These variations can be as obscure as small differences in port or chamber shape, or as obvious as the fitting of larger valves and different manifolds and camshatts. Thus it is quite possible that two identical motors with outwardly similar conversions, and identical written specifications, can in fact have quite different carburation requirements. To complicate matters even further there is still the human factor of the fuel-consumption-to-performance-ratio preference of the individual. Tuning an S.U. Carburetter installation to match an engine specification is, a matter of selecting the following items:—

- i Size and number of carburetter(s) to be used.
- ii Strength of piston spring fitted above the carburetter piston.

iii Entry of air into carburetter. i.e:—The fitting of an air cleaner system or the selection of a size and type of ram pipe, or the decision to use open-intakes.

iv Profile of jet needle.

Size of jet and range of jet needles is governed by the size of carburetter.

To be certain of obtaining the correct solutions to the above points, the engine has to be mounted on a test bed and a series of set procedures carried out. However, it is possible to arrive at a carburation setting which is reasonably close to the optimum by careful road testing and applying a given sequence to the operation.

It is advisable, after a long run with an experimental jet needle fitted, to check both spark plug appearance and condition of the tail pipe bore. In both cases 'whiteness' is a sign of weak mixture.

Having obtained a jet needle which allows the car to accelerate smoothly up to maximum revs, is steady under part throttle conditions and is also satisfactory at the top end, then consumption tests can be carried out.

These should be undertaken in good weather conditions and if the standard fuel system is used (sometimes a separate gallon tank is fitted for this purpose), fill the tank to the brim, note the mileage carefully and refill to the brim. This will give the exact quantity of

fuel used.

To obtain the best m.p.g. figures without sacrificing performance, these consumption checks should be done at steady speeds, (say 30, 40 and 50 m.p.h.), and also at top speed; then if there is excessive consumption at particular points on the needle then a closer setting can be looked for. (See back of this book), bearing in mind what part of the needle is affected.

Two last points to remember are:—

When going from weak to rich on the setting it is usual to try a dimension about .002" (two 'thou') smaller at a time, but when going from rich to weak at a point on the needle, it is advisable to go no more than .001" (one 'thou') larger on the dimensions, unless there are signs of excessive richness.

If these methods are to be used for jet needle determination please use the utmost care whilst carrying out checks on the public highways—really such road testing requires a test track.

Size of Carburetter.

An alteration in size of carburetter should only be necessary if the breathing capacity of the engine has been substantially increased. To improve the breathing will require possibly larger inlet valves, alteration to the head or ports, a change of camshaft or an increase in engine capacity.

Polishing and lining-up the ports and increasing compression by about one ratio is not really sufficient justification for increas-

ing carburetter size.

If larger instruments are to be fitted then the next size should be used; it is very rare that an engine's breathing capacity is increased to the stage where it requires an increase of two sizes. Remember if a larger instrument is fitted to a power unit which does not really merit this increase in carburetter size, the piston will not reach its full travel—the only benefit achieved will be a more impressive underbonnet appearance!

Piston spring

Piston springs are identified by a colour code and this can be found painted on the end coils of the spring.

The range for carburetters up to and including 1½" bore size is:—
2½ oz. blue. 4½ oz. red. 8 oz. yellow and 12 oz. green.

It is best to use the red spring but if the carburetters are suspected of being on the large size for an engine then the blue should be tried. Conversely if the instrument is only just large enough, a stronger yellow spring might be required.

A correct strength of piston spring will be one which allows the piston to reach its maximum travel at the point in the speed range where maximum power is obtained.

In the paper on the S.U. Carburetter given to the Institute of Mechanical Engineers by Mr. P. G. G. Knight, Technical Manager of S.U. Carburetter Co. Ltd., there is a description of a simple

piston height indicator which can be used whilst the vehicle is in motion. This device can be extremely useful in determining, both piston spring and needle profile by road test methods. (See footnote*)

It should be noted that the change from a medium spring (say the red) to a weaker one (blue), will have the effect of weakening the mixture throughout the range. The effect of going to a stronger one will be to enrich the mixture throughout the range.

A way of getting a rough guide as to which spring to use is to refer to the S.U. Leaflet AUC.9631. This lists carburetter specifications for both current and earlier models. Look down the list of vehicles and find a power unit which gives about the same power with the same number and size of carburetter fitted. This will give a piston spring/jet needle combination which can be used as a good starting point. See also appendix 1.

Carburetter air intake

The way by which the air reaches the carburetter intake can greatly affect the mixture requirements.

In addition to this manometer device Mr. Knight also refers to checking piston lift by means of a rod inserted in a hole drilled vertically through the suction chamber cap.

The rod is cut off flush with the top of the cap when piston is resting on the carburetter bridge and is therefore at its lowest point. As the piston rises, it carries the rod with it and a simple measurement reveals the extent of lift. A device of this type is actually available on the market—the PSW tool set, manufactured by PSW Test Equipment (P. M. Schleyer) of Western Germany, and imported into this country by Motor Books and Accessories, 33 St. Martins Court, St. Martin's Lane, London W.C.2. Sets are available for S.U. carburettors and for Strombergs, they cost 36s 6d. As well as piston lift, they permit immediate checks to be made of jet centralisation, synchronisation of twin carbs, mixture strength and fuel level.

Removal of an air cleaner system will tend to weaken the mixture supplied to the engine and the effect will be greater at the top end of the speed range.

The degree of weakening will depend upon the type of air cleaner and this will be governed by how much restriction the cleaner offers—the greater the restriction, the greater the weakening effect when removed. In general, oil bath type cleaners offer more restriction than the paper element types.

Fitting ram pipes to the intake flange of the carburetter(s) can also affect the mixture requirement (usually weakening the mixture slightly in the mid-speed range). The effect on power curve varies with type, and length.

There is no simple formula for ram pipe length, but in general a length of between 2 to 3 inches is used. The effect of these pipes is to boost power very slightly in the mid-speed range.

Jet needle profile.

Two leaflets which are obtainable from S.U. Carburetter Co. Ltd., or their agents, are extremely useful for jet needle determination; one is the Carburetter Specification booklet already mentioned and the other is the list of needle sizes (AUC.9618). See Appendix 2.

The book of needle sizes gives a list of diameters for each needle starting with the diameter immediately under the shank or head of the needle and working down the length in increments of one eighth of an inch. The smaller the dia-

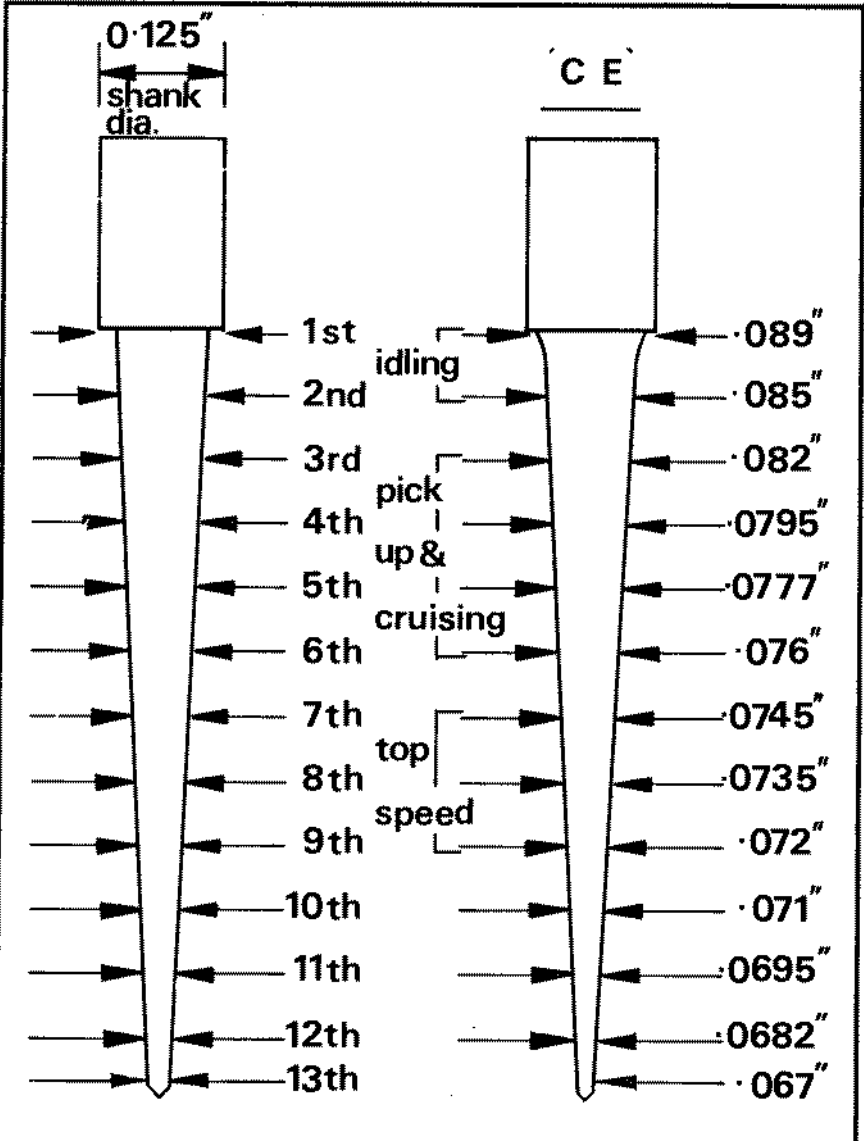

NB. The above bracketing applies for 1/4" (H2 or HS2) carburettors

meter at any particular point the richer the needle will be at that point.

To illustrate what the needle dimensions in the book actually represent we will take an example, (a diagram of this needle appears on page 10) the CE, list the dimensions and discuss which part affects which driving condition.

Referring to diagram (1) the first two dimensions are given as 1) .089 2) .085: these are the idling or datum positions and it is advisable when changing from one needle to another to choose one with the same idling dimensions.

If this is not possible then bear in mind that if the new needle has weaker or larger idling dimensions (say .089-.0855) the rest of the needle will give slightly richer results than suggested by the dimensions.

If the idling dimensions are richer or smaller (say .089-.0845) the needle will give slightly weaker results than one would expect. This is due to the alteration in the jet position required by the new idling dimensions.

The next four dimensions govern the pick up in top gear from about 20 m.p.h. to 50 m.p.h. These are 3) .082 4) .0795 5) .0777 6) .076 and are also the part of the needle which meters fuel for the part throttle or cruising conditions. A cruising speed of 30 m.p.h. will lie approximately (depending on

size of carburetter) between the second and third dimensions on the diagram; a steady 50 m.p.h. will occur around the fifth portion. Dimensions from the seventh (.0745) to the ninth (.072) affect the top end full throttle conditions. The last three dimensions (with $1\frac{1}{4}$ " diameter carburetters) do not take part in the metering.

Testing procedure

With the carburetter(s) correctly set for mixture at idle conditions (see S.U. Service Literature) and the engine oil and water at normal temperatures, carry out a number of acceleration tests and part throttle tests.

First accelerate from about 20 m.p.h. in top gear to about 50 m.p.h. If there is hesitation or a pulling back, repeat test with the choke pulled out about $\frac{5}{8}$ ". If there is an improvement, make a note that the third, fourth and fifth, and possibly the sixth needle dimensions require to be a little richer. Now try driving at a steady 30, 40 and 50 m.p.h., if there is a slight see-sawing action, try to cure this by richening the mixture control slightly.

If weakness is suspected at these cruising speeds then again the third, fourth and fifth dimensions will require richening. A similar test can be carried out for high speed in top gear. Here it is very important to ensure that there is no weakness.



SECTION II

Adjusting and Servicing

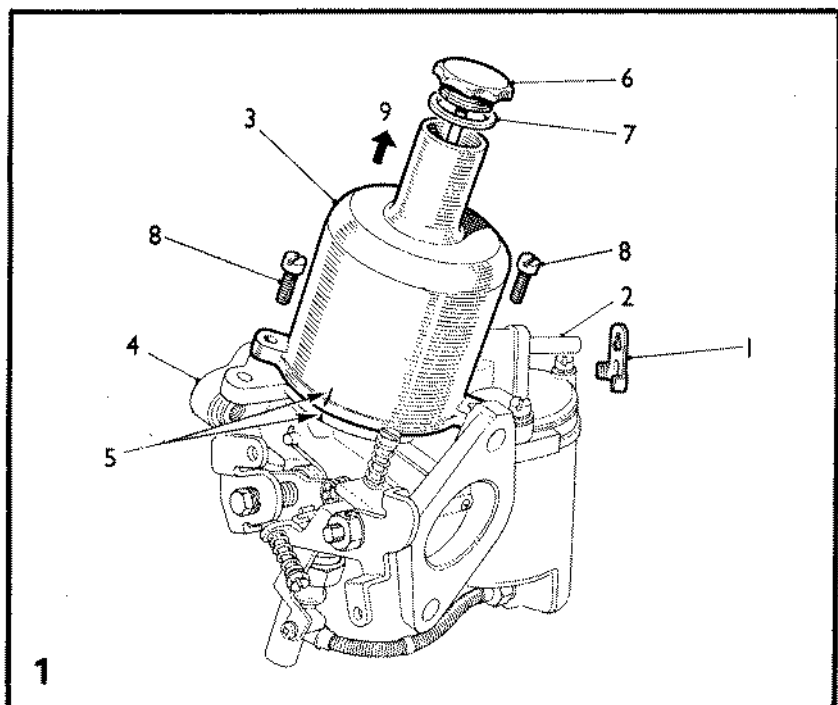

1. Baffle plate.
2. Inlet nozzle.
3. Suction chamber.
4. Carburettor body.
5. Marks for replacement.
6. Damper.
7. Damper washer.
8. Chamber retaining screws.
9. Direction of removal.

- A. Remove the baffle plate from the inlet nozzle.
- B. Thoroughly clean the outside of the carburettor.
- C. Mark the relative positions of the suction chamber and the carburettor body.
- D. Remove the damper and its washer. Unscrew the chamber retaining screws.
- E. Lift off the chamber without tilting it.

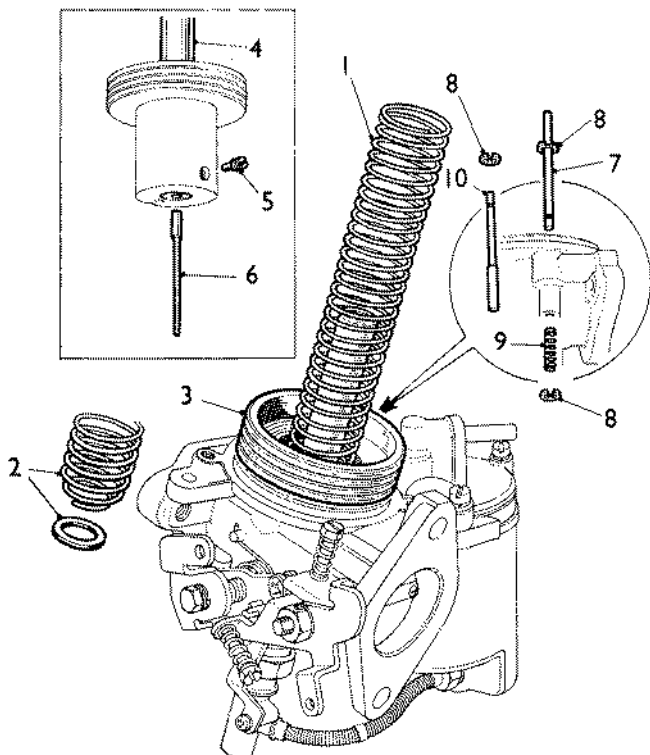

2

- | | |
|------------------------------------|------------------------------|
| 1. Piston spring. | 6. Needle. |
| 2. Alternative spring with washer. | 7. Piston lifting pin. |
| 3. Piston assembly. | 8. Circlip for pin. |
| 4. Piston rod. | 9. Spring for pin. |
| 5. Needle locking screw. | 10. Alternative lifting pin. |

- Remove the piston spring and washer (when fitted).
- Carefully lift out the piston assembly and empty the damper oil from the piston rod.
- Remove the needle locking screw and withdraw the needle. If it cannot easily be removed, tap the needle inwards first and then pull outwards. Do not bend the needle.
- If a piston lifting pin with an external spring is fitted, remove the spring retaining circlip and spring, then push the lifting pin upwards to remove it from its guide. With the concealed spring type, press the pin upwards, detach the circlip from its upper end, and withdraw the pin and spring downwards.

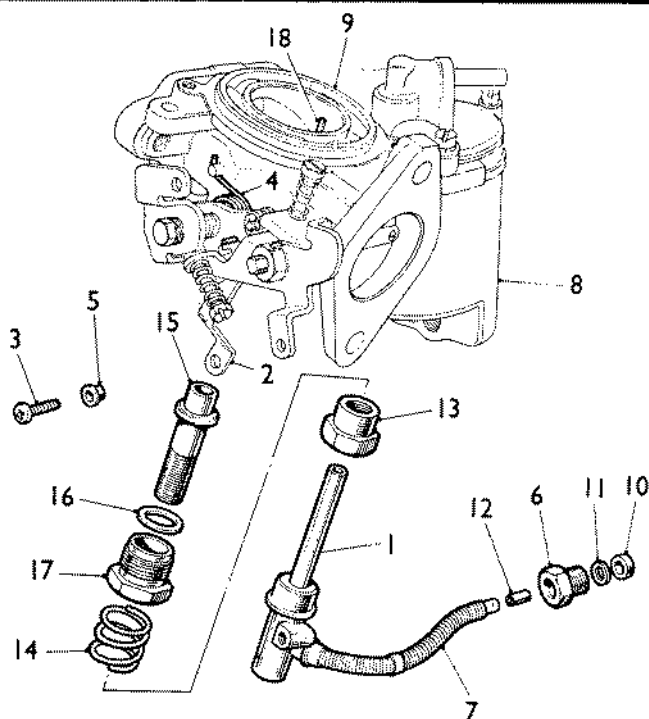

- | | |
|---------------------------------|------------------------|
| 1. Jet assembly. | 10. Gland. |
| 2. Pick-up link. | 11. Washer. |
| 3. Link retaining screw. | 12. Ferrule. |
| 4. Pick-up lever return spring. | 13. Jet adjusting nut. |
| 5. Brass bush. | 14. Spring for nut. |
| 6. Sleeve nut. | 15. Jet bearing. |
| 7. Flexible jet tube. | 16. Brass washer. |
| 8. Float-chamber. | 17. Jet locking nut. |
| 9. Carburettor body. | 18. Piston key. |

- A. Support the moulded base of the jet and slacken the screw retaining the jet pick-up link.
- B. Relieve the tension of the pick-up lever return spring from the screw and remove screw and brass bush (when fitted).
- C. Unscrew the brass sleeve nut retaining the flexible jet tube to the float-chamber and withdraw the jet assembly from the carburettor body. Note the gland, washer, and ferrule, at the end of the jet tube.
- D. Remove the jet adjusting nut and screw. Unscrew the jet locking nut and detach the nut and jet bearing. Withdraw the bearing from the nut, noting the brass washer under the shoulder of the bearing.

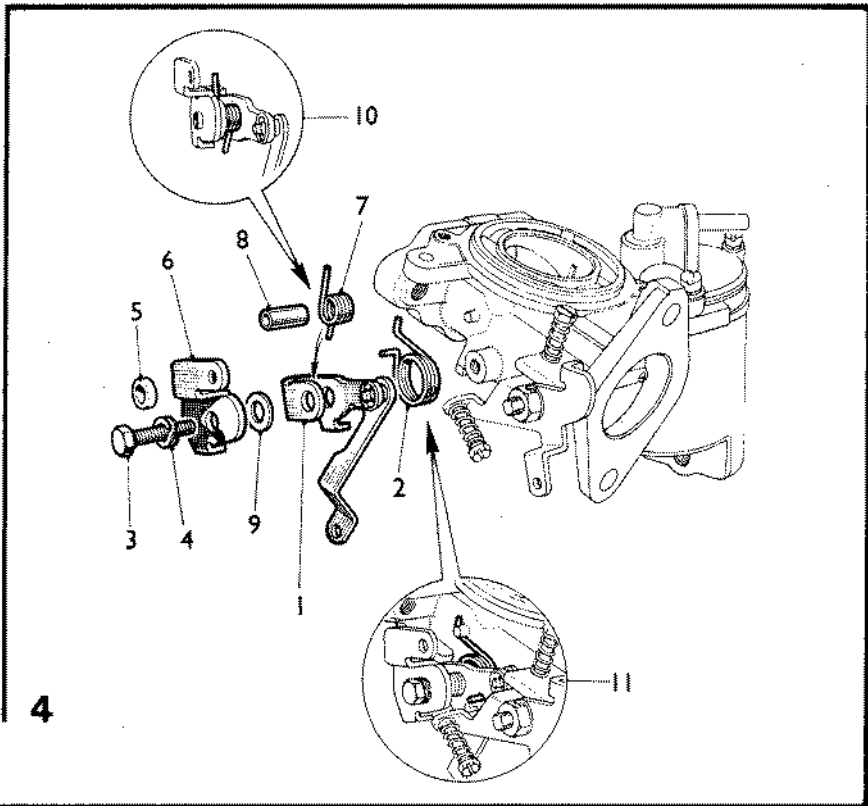

4

- | | |
|-------------------------------|------------------------------------|
| 1. Pick-up lever. | 7. Lever spring. |
| 2. Lever return spring. | 8. Pivot bolt tube. |
| 3. Lever pivot bolt. | 9. Skid washer. |
| 4. Double-coil spring washer. | 10. Cam lever spring location. |
| 5. Spacer (alternative). | 11. Pick-up lever spring location. |
| 6. Cam lever. | |

- A. Note the location points of the two ends of the pick-up lever return spring. Unscrew the lever pivot bolt together with its double-coil spring washer, or spacer. Detach the lever assembly and return spring.
- B. Note the location of the two ends of the cam lever spring and push out the pivot bolt tube or tubes, taking care not to lose the spring. Lift off the cam lever, noting the skid washer between the two levers.

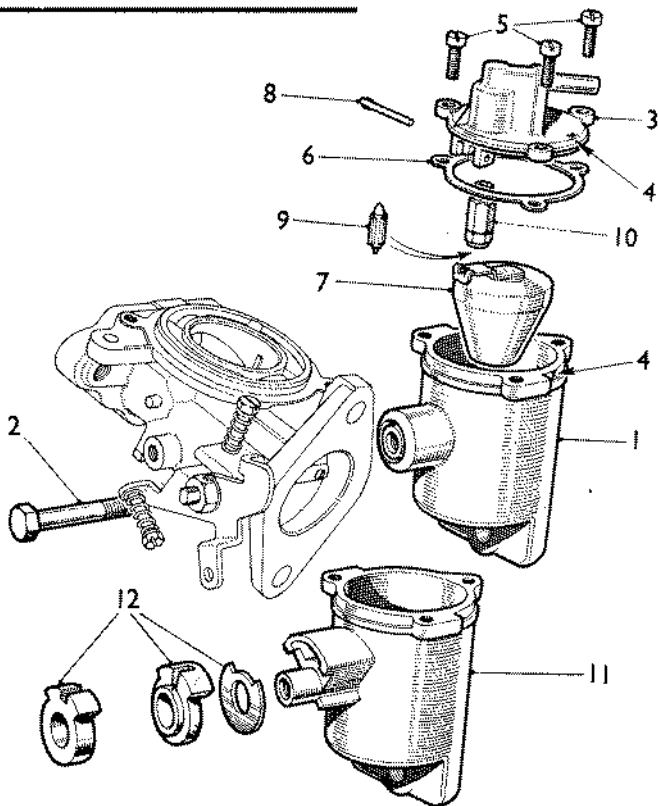

5

- | | |
|---------------------------|--------------------------------|
| 1. Float-chamber. | 7. Float assembly. |
| 2. Retaining bolt. | 8. Float hinge pin. |
| 3. Float-chamber lid. | 9. Float needle. |
| 4. Marks for replacement. | 10. Needle seating. |
| 5. Lid retaining screws. | 11. Alternative float-chamber. |
| 6. Lid gasket. | 12. Alternative spacers. |

- A. Slacken and remove the bolt retaining the float-chamber to the carburettor body. Note the component sequence with flexibly mounted chambers.
- B. Mark the location of the float-chamber lid. Unscrew the lid retaining screws and detach the lid and its gasket, complete with float assembly.
- C. Push out the float hinge pin from the end opposite its serrations and detach the float.
- D. Extract the float needle from its seating and unscrew the seating from the lid, using a box spanner .338 in. (8.58 mm.) across the flats. Do not distort the seating.

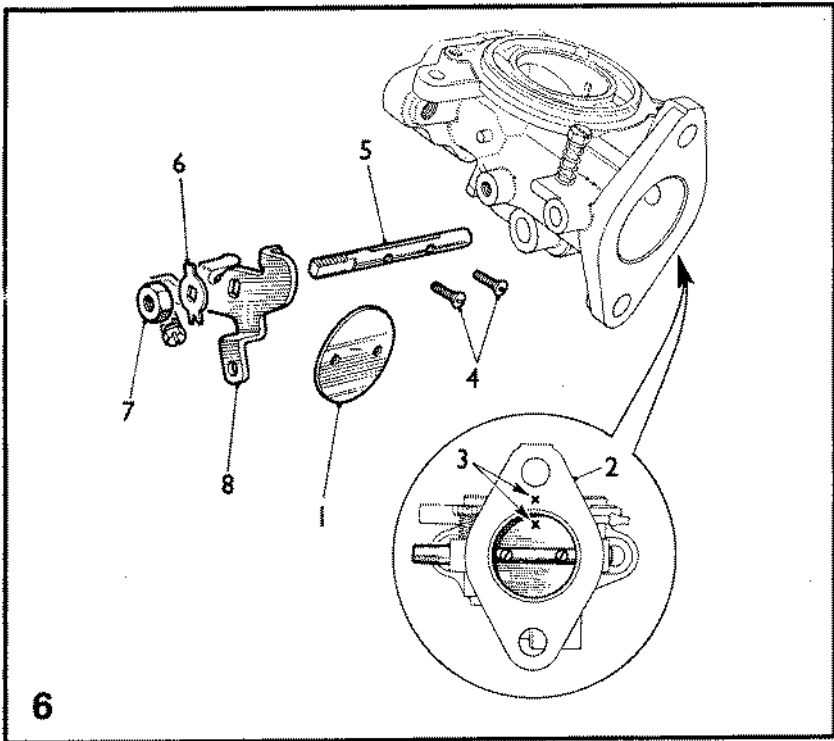

- | | |
|---------------------------|----------------------|
| 1. Throttle disc. | 5. Throttle spindle. |
| 2. Carburetter flange. | 6. Tab washer. |
| 3. Marks for replacement. | 7. Spindie nut. |
| 4. Disc retaining screws. | 8. Lever arm. |

- A. Close the throttle and mark the relative positions of the throttle disc and the carburetter flange.
- B. Unscrew the two disc retaining screws. Open the throttle and ease out the disc from its slot in the throttle spindle. The disc is oval and will jam if care is not taken.
- C. Tap back the tabs of the tab washer securing the spindle nut. Note the location of the lever arm in relation to the spindle and carburetter body; remove the nut and detach the arm.

NOTE.—Before reassembling, examine all components for damage and/or wear. Unserviceable components must be renewed.

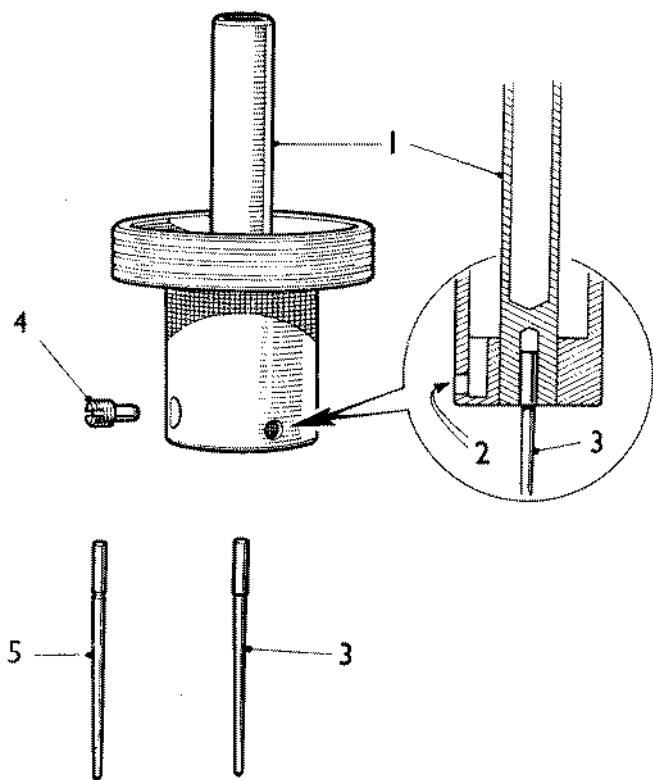

- 1. Piston rod.
- 2. Transfer holes.
- 3. Needle.
- 4. Needle locking screw.
- 5. Alternative needle.

7

8

- A. Examine the throttle spindle and its bearings in the carburettor body. Check for excessive play. Renew parts as necessary.
- B. Refit the spindle to the body. Assemble the operating lever with tab washer and spindle nut, to the spindle. Ensure that when the stop on the lever is against the abutment on the carburettor body, i.e. throttle closed position, the countersunk ends of the holes in the spindle face outwards. Tighten the spindle nut and lock with the tab washer.
- C. Insert the throttle disc in the slot in the spindle in its original position as marked. Manoeuvre the disc in its slot until the throttle can be closed and fit two new retaining screws, but do not fully tighten. Check visually that the disc closes fully, and adjust its position as necessary. With the throttle closed there must be clearance between the throttle lever and the carburettor body. Tighten the screws fully and spread their split ends just enough to prevent turning.

- A. Examine the float needle and seating for damage. Check that the spring-loaded plunger in the end of the plastic-bodied needle operates freely.
- B. Screw the seating into the float-chamber carefully. Do not overtighten. Replace the needle in the seating, coned end first. Test the assembly for leakage with air pressure.
- C. Refit the float and lever to the lid and insert the hinge pin. Check the float level as described in item 15
- D. Examine the lid gasket for re-use. Assemble the gasket on the lid and refit the lid to the float-chamber in the position marked on dismantling. Tighten the securing screws evenly.
- E. Refit the float-chamber assembly to the carburettor body and tighten the retaining bolt fully, making sure that the registers on the body and the chamber engage correctly.

9

- A. Refit the piston lifting pin, spring, and circlip.
- B. Examine the piston assembly for damage on the piston rod and the outside surface of the piston. The piston assembly must be scrupulously clean. Use petrol or methylated spirit as a cleaning agent. **Do not use abrasives.** Lightly oil the outside of the piston rod.
- C. Clean inside the suction chamber and piston rod guide using petrol or methylated spirit. Refit the damper assembly and washer. Seal the transfer holes in the piston assembly with rubber plugs or Plasticine and fit the assembly to the suction chamber. Invert the complete assembly and allow the suction chamber to fall away from the piston. Check the time this takes, which should be 3 to 5 seconds for HS2-type carburettors of 1½

10

in. (31.75 mm.) bore, or 5 to 7 seconds for larger carburetters. If the time taken is in excess of that quoted, the cause will be thick oil on the piston rod, or an oil film on the piston or inside the suction chamber. Remove the oil from the points indicated and re-check.

- D. Refit the needle to the piston assembly. The shoulder or lower edge of the groove must be level with the bottom face of the piston rod. Fit a new needle locking screw and tighten. Invert the suction chamber and spin the piston assembly inside it to check for concentricity of the needle.
- E. Check the piston key for security in the carburettor body. Refit the piston assembly to the body and replace the piston spring over the piston rod. Fit the suction chamber and retaining screws. Tighten the screws evenly.

- A. Refit the jet bearing, washer, and locking nut; do not tighten the nut. Refit the jet in its bearing and the flexible tube to the base of the float-chamber without the gland and washer.
- B. Centralize the jet as described in item 13
- C. Withdraw the jet and tube; refit the spring and jet adjusting nut. Fit the gland washer and ferrule to the flexible tube. The end of the tube should project a minimum of $\frac{1}{8}$ in. (4.8 mm.) beyond the gland. Refit the jet and tube. Tighten the sleeve nut until the neoprene gland is compressed. Overtightening can cause leakage.
- D. Refit the damper and washer.

11

- A. Reassemble the pick-up lever, cam lever, cam lever spring, skid washer, and pivot bolt tube or tubes in the positions noted on dismantling.
- B. Place the pick-up lever return spring in position over its boss and secure the lever assembly to the carburettor body with the pivot bolt. Ensure that the double-coil spring washer or spacer fits over the projecting end of the pivot bolt tube.
- C. Register the angled end of the return spring in the groove in the pick-up lever, and hook the other end of the spring around the moulded peg on the carburettor body.
- D. Fit the brass ferrule to the hole in the end of the pick-up link. Relieve the tension of the return spring and fit the link to the jet with its retaining screw. When finally tightening the screw, support the moulded end of the jet.
- E. Refit the baffle plate to the float-chamber lid nozzle.

12

JET CENTREING

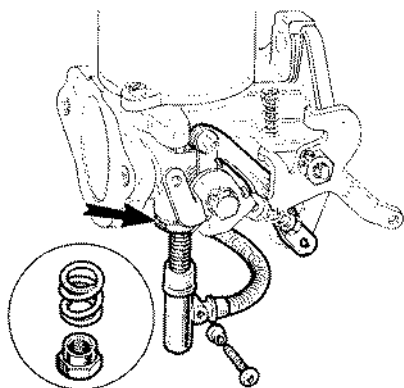

13

The piston should fall freely onto the carburettor bridge with a click when the lifting pin is released with the jet in the fully up position. If it will only do this with the jet lowered then the jet unit requires re-centring. This is done as follows:

- A. Remove the jet head screw to release the control linkage.
- B. Withdraw the jet, disconnecting the fuel feed pipe union in the float-chamber, and removing the rubber sealing washer. Remove the jet locking spring and adjusting nut.
- C. Replace the jet and insert the fuel feed pipe connection into the float-chamber.
- D. Slacken the jet locking nut until the assembly is free to rotate.

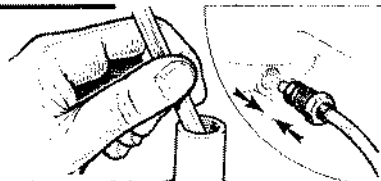

- A. Remove the piston damper and apply pressure to the top of the piston rod with a pencil.
- B. Tighten the jet locking nut keeping the jet hard up against the jet bearing.
- C. Finally check again as in item 13.
- D. Re-fit the jet locking spring and adjusting nut. Before replacing the fuel feed pipe into the float-chamber, fit the rubber sealing washer over the end of the plastic pipe so that at least $\frac{1}{8}$ in. (4.8 mm.) of pipe protrudes (see inset). Reassemble the controls.
- E. Refill the piston dampers with the recommended engine oil (see Item 26).

14

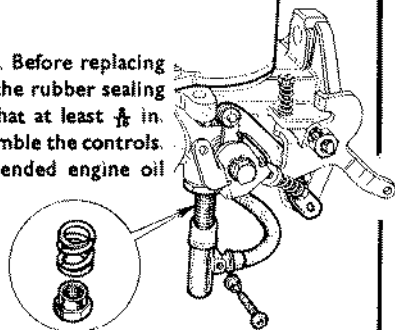

Float-chamber fuel level

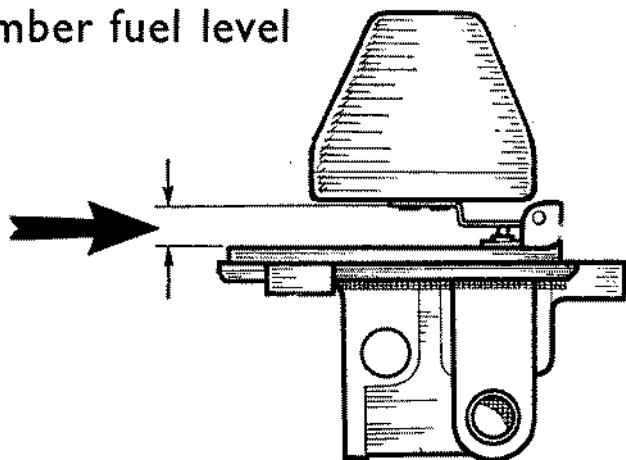

- A. Remove and invert the float-chamber lid.
- B. With the needle valve held in the shut-off position by the weight of the float only, there should be a $\frac{1}{8}$ to $\frac{1}{16}$ in. (3.2 to 4.8 mm.) gap between the float lever and the rim of the float-chamber lid.
- C. The float may be set by bending at the crank.

15

ROUTINE CLEANING

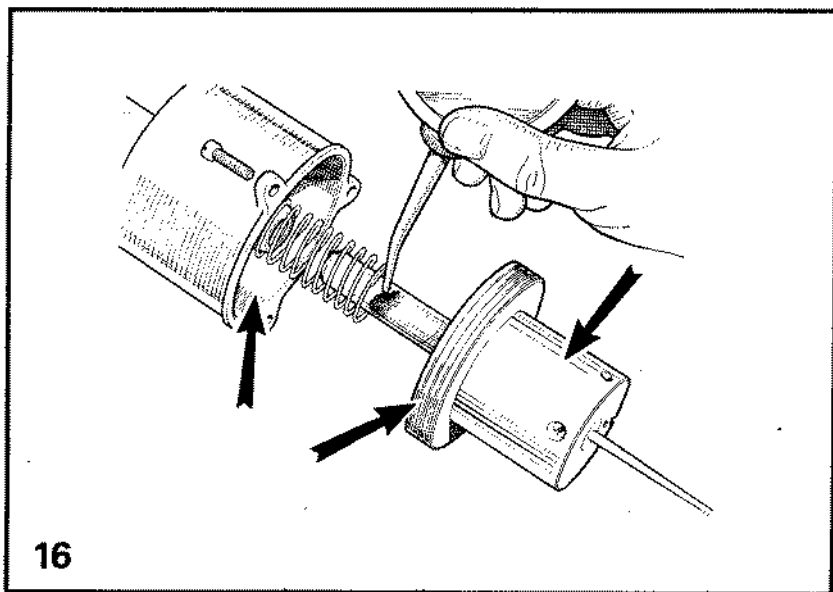

16

- A. At the recommended intervals mark for reassembly and carefully remove the piston/suction chamber unit.
- B. Using a petrol-moistened cloth, clean the inside bore of the suction chamber and the two diameters of the piston.
- C. Lightly oil the piston rod only and reassemble as marked.
- D. Refill piston damper (see item 26)

SECTION III

Tuning Multi Carburetters

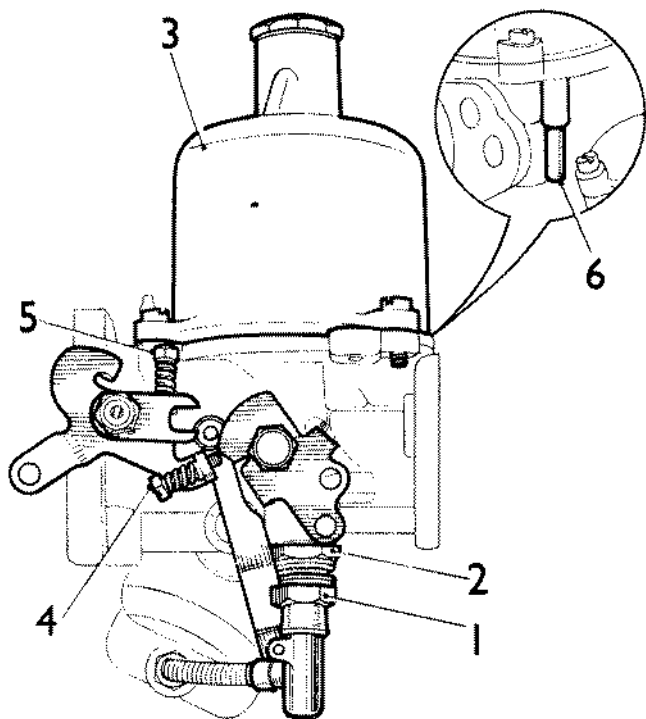

The Type HS Carburetter

- | | |
|----------------------------|-------------------------------|
| 1. Jet adjusting nut. | 4. Fast-idle adjusting screw. |
| 2. Jet locking nut. | 5. Throttle adjusting screw. |
| 3. Piston/suction chamber. | 6. Piston lifting pin. |

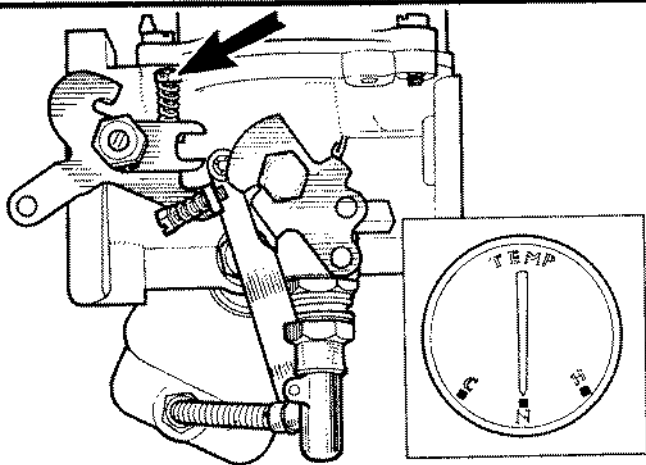

- 17**
- A Warm engine up to normal temperature.
 - B Switch off engine.
 - C Unscrew the throttle adjusting screw until it is just clear of its stop and the throttle is closed.
 - D Set each throttle adjusting screw $\frac{1}{4}$ of a turn open.

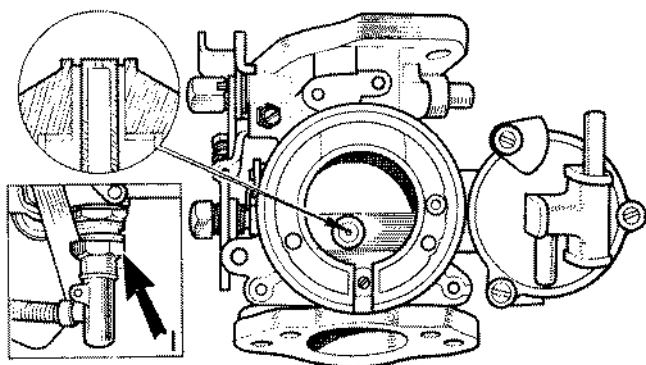

- A. Mark for reassembly and remove piston/suction chamber unit.
- B. Disconnect mixture control wire.
- C. Screw the jet adjusting nut (1) until the jet is flush with the bridge of the carburettor or fully up if this position cannot be obtained.
- D. Replace the piston/suction chamber unit as marked.
- E. Turn down the jet adjusting nut (1) two complete turns.

18

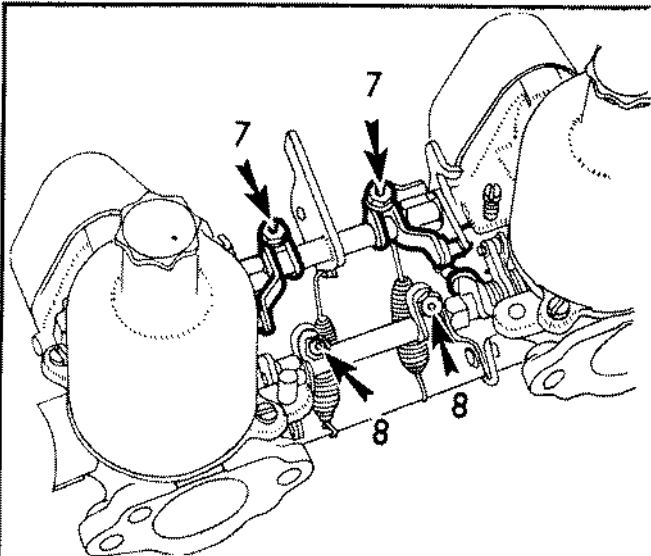

- 19**
- A. Slacken both of the clamping bolts (7) on the throttle spindle interconnections.
 - B. Disconnect the jet control interconnection by slackening the clamping bolts (8).

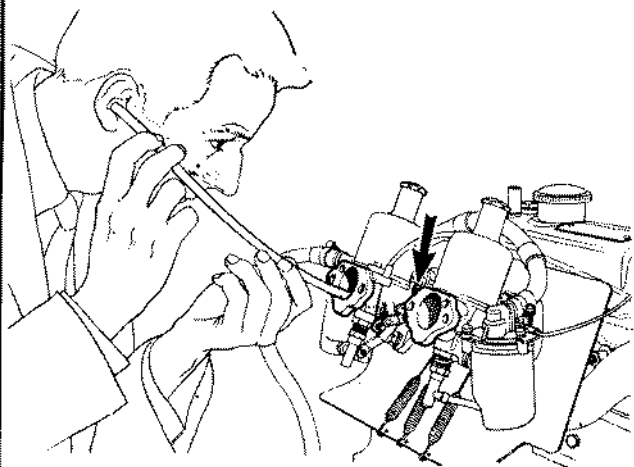

- 20**
- A. Restart the engine and adjust the throttle adjusting screws on each carburetter to give the desired idling speed as indicated by the glow of the ignition warning light.
 - B. Compare the intensity of the intake 'hiss' on all carburetters and alter the throttle adjusting screws until the 'hiss' is the same.

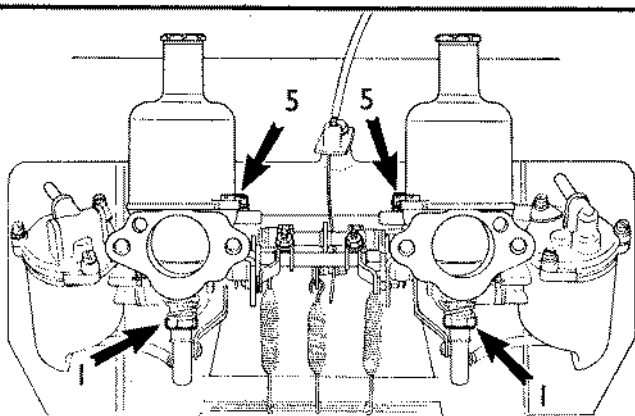

21

- A. Turn the jet adjusting nuts (1) on all carburetters up to weaken or down to richen the same amount until the fastest idling speed consistent with even running is obtained.
- B. Readjust the throttle adjusting screws (5) to give correct idling if necessary.

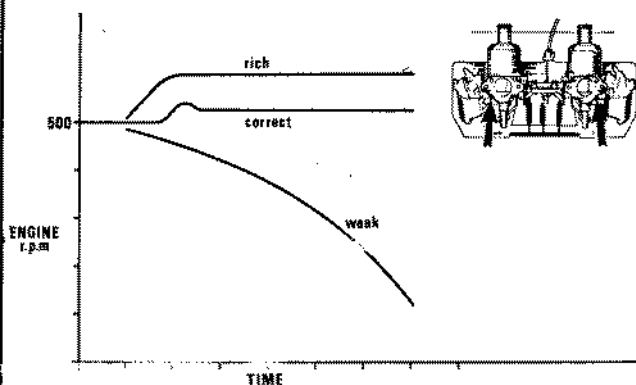

22

- A. Check for correct mixture by gently pushing the lifting pin of the front carburetter up $\frac{1}{2}$ in. (.8 mm.) after free movement has been taken up. The graph illustrates the possible effect on engine r.p.m. Readjust the mixture strength if necessary.
- B. Repeat the operation on the other carburetters and after adjustment re-check since they are all inter-dependent.
- C. Item 25. shows the correct type of exhaust smoke.

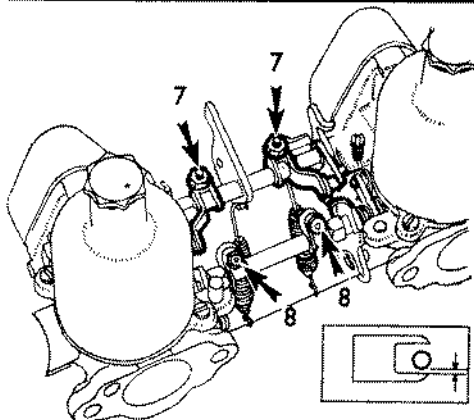

23

- A. Set the throttle interconnection clamping levers (7) so that the link pin is .012 in. (.30 mm.) away from the lower edge of the fork (see inset). Tighten the clamp bolts.
- B. With both jet levers at their lowest position, set the jet interconnection lever clamp bolts (8) so that both jets commence to move simultaneously.

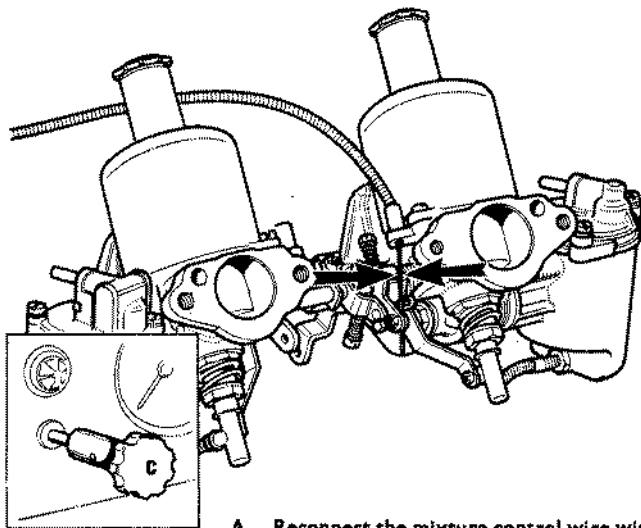

24

- A. Reconnect the mixture control wire with about $\frac{1}{8}$ in. (1.6 mm.) free movement before it starts to pull on the jet levers.
- B. Pull the mixture control knob until the linkage is about to move the carburetor jets, and adjust the fast idle screws, comparing the intensity of the air intake 'hiss' to give an engine speed of about 1,000 r.p.m. when hot.
- C. Refit the air cleaners.

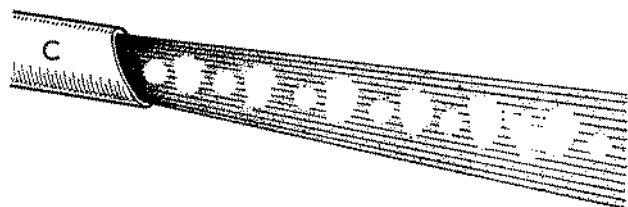
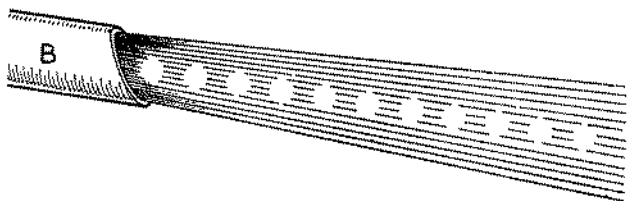
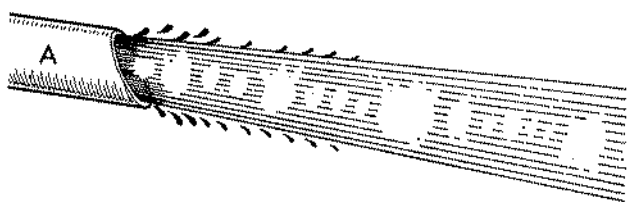

25

The effect of mixture strength on exhaust smoke

- A. **TOO WEAK:** Irregular note, splashy misfire, and colourless.
- B. **CORRECT:** Regular and even note.
- C. **TOO RICH:** Regular or rhythmical misfire, blackish.

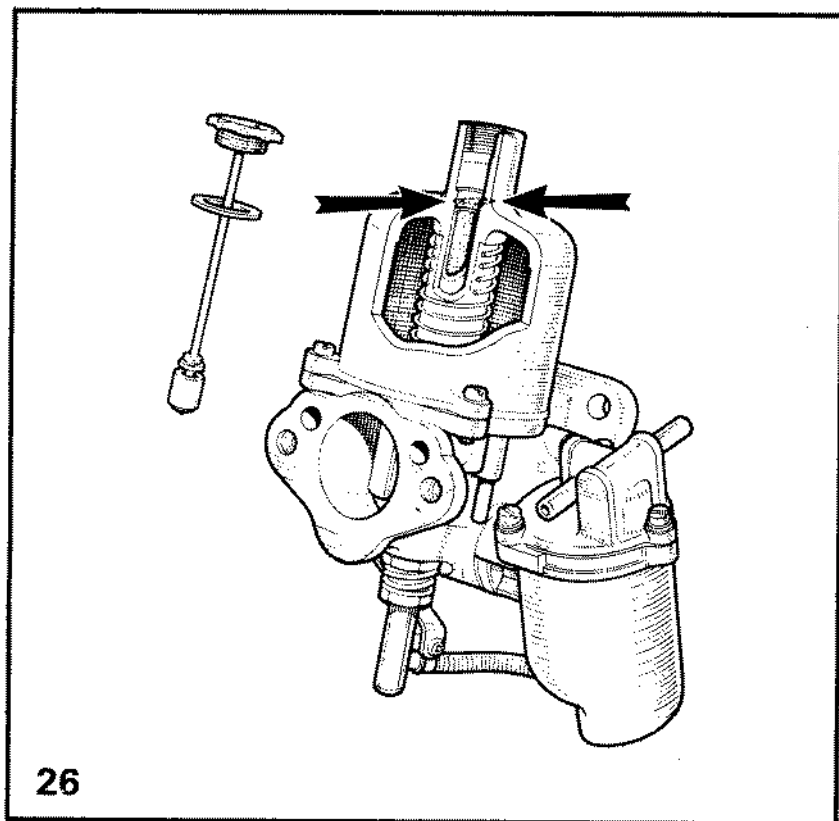

Finally top up the piston damper with the recommended engine oil until the level is $\frac{1}{2}$ in. (13 mm.) above the top of the hollow piston rod.

Note

On dust-proofed carburetters, identified by a transverse hole drilled in the neck of the suction chambers and no vent hole in the damper cap, the oil level should be $\frac{1}{2}$ in. (13 mm.) below the top of the hollow piston rod.

S.U. carburetter specifications Appendix 1

AUSTIN HEALEY	CAR MODEL	YEAR	TYPE No.	NEEDLE		SPRING COLOUR
				RICH STD.	WK.	
2963 c.c.	Austin-Healey 100BN2	1953/6	Pair H4	QA	OW	Yellow
	Austin-Healey Le Mans	1954/6	Pair H6	OA6	OA7	Red
	Austin-Healey 100 S	1955	Pair H6	KW	KWI	Red
2639 c.c.	Austin-Healey 100/6 BN4	1957	Pair H4	4	AJ	Red
2912 c.c.	Austin-Healey BN6 3000 (Mk. I)	1959	Pair HD6	RD	CV	Yellow
	Austin-Healey BN7	1959	Pair HD6	RD	CV	Green
	Austin-Healey BN7	1959	Pair HD6 Thermo	RD	CV	Green
	Austin-Healey BN7 (RC)	1960	Pair HD6	RD	CV	Green
2912 c.c.	Austin-Healey BN7 (Mk. II)	1961/2	Three HS4	DK	DJ	Red
2912 c.c.	Austin-Healey 3000 (Mk. II)	1962/3	Pair HS6	DK	BC	Green
2912 c.c.	Austin-Healey BJ8-(Mk. III)	1964	Pair HD8	UN	UH	Red/Green
	Sprite	1959	Pair H1	EB	GG	Red
	A 99	1959/61	Pair H4	M5	HA	Yellow
848 c.c.	Seven (Mini)	1959	Single HS2	M	EB	Red
848 c.c.	Seven and Super	1961/2	Single HS2	M	EB	Red
997 c.c.	Mini-Cooper	1961/2	Pair HS2	AH2	GZ	Red
1622 c.c.	A 60	1961/4	Single HS2	M	GX	Yellow
948 c.c.	A 40	1961/2	Single HS2	AH2	M	Red
948 c.c.	Healey Sprite (Mk. II)	1961/2	Pair HS2	V2	V3	Blue
1038 c.c.	Healey Sprite (Mk. II)	1962/3	Pair HS2	M	GY	Blue
1098 c.c.	Healey Sprite (Mk. III)	1963/4	Pair HS2	H6	AN	Blue
1275 c.c.	Healey Sprite (Mk. IV)	1966	Pair HS2	H6	AN	Blue
948 c.c.	A 35 Van	1962/3	Single HS2	H6	AN	Red
1098 c.c.	A 40 and Austin 1100	1962/4	Single HS2	H6	AN	Red
1070 c.c.	Mini-Cooper S	1963/4	Pair HS2	3	H6	Red
1275 c.c.	Mini-Cooper S	1964	Pair HS2	AH2	M	Red
970 c.c.	Mini-Cooper S	1964	Pair HS2	H6	AN	Red
998 c.c.	Mini-Cooper	1964	Pair HS2	M	GY	Blue
1800 c.c.	Austin 1800	1964	Single HS6	SW	TW	Yellow
850 c.c.	A 35 Van	1965/6	Single HS2	M	EB	Red
1098 c.c.	Mini Automatic	1965/6	Single HS4	H6	AN	Red
1098 c.c.	1100 Automatic	1965/6	Single HS4	BG	DL	Red
1800 c.c.	1800	1966	Single HS6	SW	TW	Yellow

Appendix 1 contd

CAR MODEL	YEAR	TYPE No.	RICH STD.	NEEDLE WK.	SPRING COLOUR
CONVERSION SETS					
M.G.—Elva	1959/61	Pair H4	GS		Red
B.M.C. A Series—Turner	1959/61	Pair H1	BXI		
Minor 1000—Speedwell	1959/61	Pair H2	M8		Blue
B.M.C. A Series—Turner	1959/61	Pair H2	M6		Red
Sprite-Sebring	1960	Pair H2	GX		Blue
F2 Cooper Climax S/C	1960	Single H8			
B.M.C.—F.J. Cooper	1960	Pair H4	AM		Blue
Alexander Herald	1960/1	Pair H2	M6		Blue
Sprite	1960	Pair H4	A5		Blue
Mangoletsi Remix	1961/3	Pair H1	M8		
Healey 3000 Competition	1961	Three HD8	UH		Blue/Black
Mini Cooper (Thermo jets)	1961/3	Pair H4	MME		Blue
Sprite—Speedwell	1962/3	Pair H4	AO		Red
Mini competition	1962/3	Pair H4	MME		Blue
Mini-Cooper S Group 2	1964	Pair H4	CP4		Blue
Mini-Cooper S Group 2	1964	Pair H4	MME		Blue
Mini-Cooper S Group 2	1964	Pair H4	BG		Blue
Formula 3 B.M.C.-Cooper	1964	Single HS6	SS		Red
Morris 1100 (Downton)	1964	Pair H4	AM		Blue
COVENTRY CLIMAX					
1100 c.c.	1954/8	Pair H4	R6	BE 6	Blue
F.W.A. Stage I		Pair H4	BE	BE	Blue
F.W.A. Stage II		Pair H4	BF	BF	Blue
Lotus Elite		Pair H4	BQ	BQ	Blue
Lotus Elite		Pair H4	BF	BF	Blue
F.P.F.		Single H4	ZB	ZB	Yellow
		Pair DU6			
FORD (CONVERSIONS)					
1172 c.c. E93A	1949/53	Pair HV1	M9	EK	MOW
1172 c.c. 100E Aquasport	1953/7	Pair MC2	MI	A5	HA
1172 c.c. 100E Prefect and Anglia	1953	Pair H1	M6	M6	Red
1172 c.c. 100E Lotus	1954/60	Pair H2	M5	M6	M7

CAR MODEL (CONVERSIONS)	YEAR	TYPE No.	RICH	NEEDLE STD.	WK.	SPRING COLOUR
Consul—Aquaplane (Series 1)	1954/7	Pair H4	4	3	L	Red
Consul—W.H.M.B. Ltd.	1955/7	Pair H2	H2	OA	OW	Red
Zephyr—Aquaplane (Series 1)	1954/7	Three H4	4	3	L	Yellow front and rear
Zephyr—W.H.M.B. Ltd.	1955/7	Three H2	EM	ES	AP	Red
Zephyr—Raymond Mays (Series 1)	1954/6	Pair H4	CN	5	GE	Yellow
Zephyr—Raymond Mays (Series 2)	1957/62	Pair H4	MME	7	AO	Yellow
Consul—R. Owen (Series 2) 4 port head	1958/60	Single H6		RB		Red
Consul—R. Owen (Series 2) 6 port head	1958/60	Pair H6		RB		Red
105E FJ	1060/2	Pair H4		AM		Blue
100E Aquaplane	1960/2	Pair H2		GX		Blue
105E/107E Aquaplane	1960/2	Pair H2		A5		Blue
Consul—R. Owen (Series 2) 4 port head	1962	Pair H2		RB		Red
Zephyr—Raymond Mays	1962	Single H6		AY		Yellow
E93A—Dellow	1950	Pair H4		RLS		Red
Consul (Series 1)—Dellow	1953	Single HV3		M5		Red
Zephyr (Series 1)—Dellow	1954	Pair H2		M5		Red
100E Prefect and Anglia—Dellow	1955	Three H2		M5		Red
V.8 (Special adaptor)	1955	Pair H1	M9	EK	MOW	Red
Consul (Series 1)	1950	Pair H4	RO	6		Red
	1952	Pair H4 DD		61		Yellow
Consul (Series 1)	1953	Pair H2 DD		62		Yellow
Zephyr (Series 1)	1953	Three H2 DD		WX		Yellow
Lotus 105E	1961/2	Pair H2		A5		Blue
Turner/Classic	1961/2	Single HS4		DJ		Red
Reliant Ford	1962/3	Pair HS4		CZ		Red
Reliant Zephyr 4	1963/4	Pair HS4		DH		Red
Formula 3 (Holbay-Ford)	1964	Single HS6		UVP		Red

30 h.p.

Appendix 1 contd

CAR MODEL	YEAR	TYPE No.	RICH	NEEDLE STD.	WK.	SPRING COLOUR
HILLMAN						
875 c.c.	1964	Pair HS2		H4		Blue
1600 c.c.	1964	Pair H4		QA		Red
1390 c.c.	1956/8	Pair H2	CU	CZ	CF	Blue
Alexander Minx (Conversion)	1959/61	Pair H2		GR		Blue
JAGUAR						
XK 120	1949/50	Pair H6 Thermo		R8		Red
XK 120	1951/4	Pair H6 Thermo		RF	RG	Red
XK 120 (Remote air cleaner)	1951/4	Pair H6 Thermo	53	WO2	WO3	Red
XK 120 7:1 and 8:1 C.R.C. Type	1952	Pair H8	75	VR	VE	Black/Red
XK 120 8:1 C.R.C. Type	1952	Pair H6 Thermo		RG		Red
XK 120 8:1 C.R. (Remote air cleaner)	1952	Pair H6 Thermo		DG		Red
XK 120 9:1 C.R.C. Type	1952	Pair H6 Thermo		RC		Red
XK 140 7:1 and 8:1 C.R.	1954	Pair H6 Thermo	SA	SJ	LBA	Red
XK 130 C.7:1 and 8:1 C.R. (C Type head)	1954	Pair H6 Thermo		SR		Red
XK 140C 7:1 and 8:1 C.R. (C Type Head)	1954	Pair H6 Thermo		WO2		Red
disc air cleaners	1954	Pair H8		VR	VE	Black/Red
XK 140C 8:1 and 9:1 C.R. (C head)	1954	Pair H6 Thermo	75	WO2		Red
XK 140C 7:1 and 8:1 C.R. D/H Coupé and standard	1955	Pair H6 Thermo		WO2		Red
XK 140C 7:1 and 8:1 C.R. R.H.D. F/H Coupé	1955	Pair H6 Thermo		WO2		Red
XK 140C 7:1 and 8:1 C.R. L.H.D. F/H Coupé	1955	Pair H6 Thermo		WO2		Red
XK 140 7:1 and 8:1 C.R. L.H.D. F/H Coupé	1955	Pair H6 Thermo	SA	SJ	LBA	Red
XK 140 7:1 and 8:1 C.R. R.H.D. F/H Coupé	1955	Pair H6 Thermo	SA	SJ	LBA	Red
XK 140 7:1 and 8:1 C.R. R.H.D. F/H Coupé	1955	Pair H6 Thermo	SA	SJ	LBA	Red
XK 140 7:1 and 8:1 C.R. Borg-Warner	1955	Pair H6 Thermo	SA	SJ	LBA	Red
XK 140 7:1 and 8:1 C.R. Borg-Warner R.H.D. F/H Coupé	1956	Pair H6 Thermo	SA	SJ	LBA	Red
XK 140 7:1 and 8:1 C.R. Borg-Warner L.H.D. D/H Coupé	1956	Pair H6 Thermo	SA	SJ	LBA	Red
XK 140 7:1 and 8:1 C.R. Borg-Warner R.H.D. D/H Coupé	1956	Pair H6 Thermo	SA	SJ	LBA	Red
XK 150 S	1959/62	Three HD8 Thermo		UE		Blue/Black
XK 150	1959	Pair HD6 Thermo	WO3	TL	SJ	Red
XK 150	1960/2	Pair HD6 Thermo	WO3	TL	SJ	Red
XK 150	1960/2	Pair HD6 Thermo		TU		Red
E Type	1961/4	Three HD8	UM	UM		Blue/Black
E Type	1965	Three HD8	UM	UM		Blue/Black
3-4 litre						
3-4 litre						
3-8 litre						
3-8 litre						
4-2 litre						

CAR MODEL	YEAR	TYPE & No.	RICH	NEEDLE STD.	WK.	SPRING COLOUR
M.G.						
1250 c.c.	1954/5	TF (end 1.5 litre)	HI	GJ	GL	Blue
	1954/5	ZA Megnette	M	GM	GO	Red
1500 c.c.	1955/9	MGA	CC	GS	4	Red
	1956/8	ZA/ZB Megnette		EQ	M5	Red
	1958	Twin Cam	RH	OA6	OA7	Red
1588 c.c.	1959/61	Megnette III	FT	FU	M9	Red
	1959/62	Pair HD4	RO	6	AO	Red
1588 c.c.	1961/3	MGA (Marks I and II)	FU	HB	FK	Red
1622 c.c.	1961/3	Megnette (Mk. IV)	V2	V3	GX	Blue
948 c.c.	1961/2	Midget	D6	D3	GV	Blue
1098 c.c.	1962/3	1100	M	GY	GG	Blue
1098 c.c.	1962/3	Midget	6	MB	21	Red
1800 c.c.	1962/3	MGB		UVD		Blue/Black
	1963/4	MGB Competition	6	5	21	Red
1800 c.c.	1966	MGB and GT	H6	AN	GG	Blue
1098 c.c.	1964	Midget Mk. II				

MORRIS

Minor (Series II) O.H.V.	1953/6	Single H1	EB	GG	MOW	
Minor 1000	1957	Single H2	S	BXI	MO	Red
Minor 1000 (paper air cleaner)	1957	Single H2	AH2	M	EB	Red
Minor 1000 (rubber fuel line)	1957	Single H2	S	BXI	MO	Red
Minor 1000 (rubber fuel line and paper cleaner)	1957	Single H2	M	M		Red
Minor 1000 (steel levers)	1958	Single H2	S	BXI	MO	Red
Minor 1000 (steel levers, paper air cleaner)	1958/9	Single H2	AH2	M	EB	Red
Mini Minor	1959/62	Single HS2	M	EB	GG	Red
848 c.c.	1960/2	Single HS2	AH2	M	EB	Red
948 c.c.	1962/3	Single HS2	H6	AN	EB	Red
1098 c.c.	1960/2	Single HS2	AH2	M	EB	Red
*Replacement for Minor 1000						
Twin carburettor sets						
Minor MM and Series II—Derrington	1948/56	Pair UBA	M9	EK	MOW	
Oxford MO Series II/III—Derrington	1950/7	Pair H2	YJ	HB	MO	Red
Minor—Power Drive and Alexander	1957	Pair H1	EB	GG	MOW	
Series II Minor	1953/6					

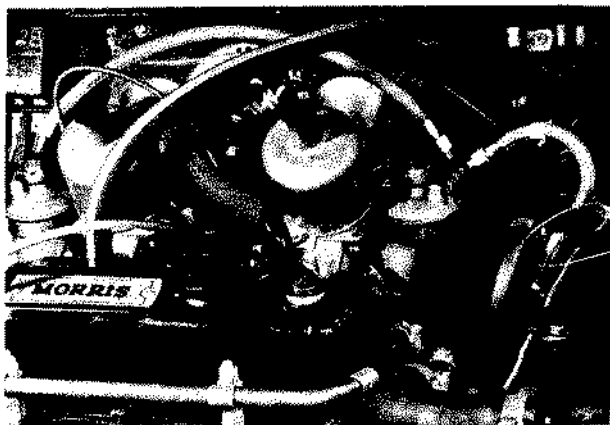

A works Mini Cooper S: within the engine department lurk these twin $1\frac{1}{2}$ ins SUs in place of the standard $1\frac{1}{4}$ ins. carbs. Note the carb bellmouths and the re-routed oil breather pipe all very neatly done.

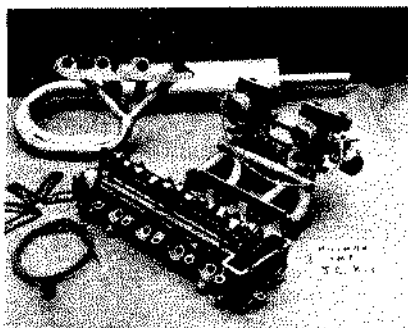

Above: twin $1\frac{1}{2}$ ins. SUs as supplied by Nerus for the Imp, other well known tuners sell this type of conversion for about £30 and results are generally good. Below: HS6s ($1\frac{1}{2}$ ins.) as fitted to the MGC; its sister the MGB uses the visually similar $1\frac{1}{4}$ ins. twin HS4 carbs.

Below: these twin $1\frac{1}{2}$ ins. SUs were fitted to an MGB tuned by Bill Nicholson of Northampton. Together with other mods they helped propel it to a 0-60 time of 8.8 secs.

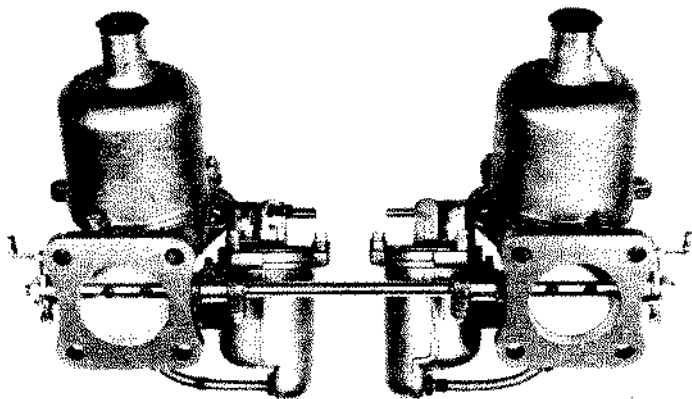

Appendix I contd

CAR MODEL	YEAR	TYPE & No.	RICH	NEEDLE STD.	WK.	SPRING COLOUR
RILEY						
1489 c.c.	1957/64	Pair H4	AR	AD	HA	Red
1489 c.c.	1957/62	Pair H4	AR	AD	HA	Red
1498 c.c.	1959/61	Pair HD4	FT	FU	M9	Red
848 c.c.	1961/2	Single HS2	M	EB	GG	Red
1622 c.c.	1961/4	Pair HD4	FU	HB	FK	Red
998 c.c.	1963/4	Single HS2	M	GX	GG	Red
1098 c.c.	1965/6	Pair HS2	D6	D3	GV	Blue
1275 c.c.	1967	Single HS4	BO	DZ	CF	Red
ROVER						
2 litre	2000					
2 litre	2000 (Smith's valve)	Single HS6		RN		Green
2 litre	2000 TC	Single HS6		RR		Green
STANDARD						
9 h.p. and 10 h.p.	1955/6	Pair H1		U1		Black/Blue
TRIUMPH						
TR2	1953/5	Pair H4	GER	D3		
1991 c.c.	1956/8	Pair H6	RH	FV	CR	Red
948 c.c.	1959/61	Pair H1	EB	SM	SL	Red
1991 c.c.	1959/62	Pair H6	RH	GV	CA	Red
1147 c.c.	1962/3	Pair HS2	RH	SM	SL	Red
2-2 litre	1965/6	Pair HS6	H6	AN	EB	Red
1147 c.c.	1966	Pair H4	SW	TW	CIW	Red
	1963/4	Pair HS2		DB		Blue
				MO		Red

.090 JET NEEDLES

APPENDIX 2

AS	AA	AB	AC	AC2	AD	AE	AY	AZ	AAA	AAA cont.			
.089	.089	.089	.089	.088	.089	.089	.089	.089	.089	.050			
.085	.0845	.085	.085	.084	.085	.085	.085	.085	.085	.048			
.0826	.080	.080	.082	.082	.082	.081	.0805	.0815	.0814	.046			
.080	.0767	.0785	.080	.080	.080	.078	.0768	.079	.0735				
.0782	.0725	.0768	.0783	.0783	.0780	.0763	.0741	.0755	.0755				
.0765	.071	.075	.0765	.0765	.0760	.0754	.072	.071	.072				
.0746	.0689	.0732	.0746	.0746	.0740	.0745	.0694	.0662	.0674				
.073	.0661	.0718	.073	.073	.0720	.0737	.0669	.0615	.063				
.0711	.0638	.0702	.071	.071	.070	.0728	.0643	.0575	.060				
.0694	.0614	.0689	.0694	.0694	.0680	.0718	.0617	.0532	.058				
.0676	.0591	.0671	.0676	.0676	.066	.071	.059	.0490	.056				
.065	.0566	.0657	.066	.066	.064	.070	.0565	.0445	.0540				
	.054	.064	.064	.064	.062		.0538	.0405	.052				
AF	AG	AH	AH1	AH2	AI	AJ	BA	BB	BD	BE	BF	BG	BH
.089	.089	.088	.088	.089	.089	.089	.090	.089	.090	.089	.089	.089	.089
.085	.085	.0862	.086	.085	.085	.085	.0856	.085	.086	.084	.085	.085	.085
.0814	.0795	.083	.082	.082	.082	.0817	.0822	.0825	.0822	.0805	.082	.0815	.0812
.078	.0745	.0803	.079	.0794	.0798	.079	.0805	.080	.0805	.0773	.0796	.0782	.0775
.0758	.0702	.0725	.0765	.077	.078	.0767	.0794	.0775	.0794	.074	.0764	.0745	.0753
.0727	.0665	.0756	.075	.0748	.0765	.0745	.0777	.075	.0777	.0705	.072	.0695	.074
.071	.063	.0733	.073	.0726	.075	.0723	.0760	.0725	.0760	.067	.068	.0647	.0731
.0695	.0598	.0711	.071	.0704	.0732	.0703	.0743	.070	.0750	.0634	.0635	.060	.0722
.068	.0567	.069	.069	.0683	.0712	.0683	.0727	.0675	.0740	.060	.0591	.0557	.0714
.0665	.054	.067	.067	.0662	.0693	.0663	.0710	.065	.0730	.0565	.0549	.0515	.0705
.065	.051	.065	.065	.064	.0683	.064	.0694	.0625	.0720	.053	.0505	.0474	.0696
.0632	.0485	.063	.063	.062	.0675	.062	.0677	.060	.0710	.0495	.0463	.043	.0688
	.046	.061	.061	.060				.0575		.046	.042	.039	.068
AK	AL	AM	AN	AO	AP	AQ	BI	BJ	BK	BL	BM	BN	BO
.089	.089	.089	.089	.089	.089	.089	.089	.089	.089	.089	.089	.089	.089
.086	.085	.085	.0855	.085	.085	.085	.0855	.0855	.0855	.0855	.0855	.0855	.0855
.0825	.0816	.081	.0827	.082	.0817	.080	.0808	.0824	.0815	.081	.0805	.0816	.0835
.0795	.0796	.078	.0807	.0793	.0796	.076	.0777	.0794	.0785	.0777	.0768	.0784	.0815
.0786	.0781	.0753	.0787	.0766	.0777	.0724	.0751	.0769	.0762	.075	.074	.0738	.080
.078	.077	.073	.077	.0737	.0765	.0694	.073	.0749	.0738	.073	.072	.0738	.0787
.077	.076	.0704	.0753	.0705	.0752	.0668	.0714	.0734	.0722	.0715	.0705	.0724	.077
.0764	.0748	.068	.074	.0673	.0745	.0642	.0705	.0725	.0715	.0707	.0695	.0714	.0757
.0755	.0738	.0655	.073	.064	.0736	.062	.0701	.0721	.071	.070	.0692	.0707	.075
.0747	.0726	.063	.072	.0608	.0727	.060	.0697	.0717	.0706	.0698	.0698	.0703	.074
.0738	.0715	.0606	.071	.0576	.072	.058	.0694	.0714	.0703	.0693	.0684	.0701	.073
.073	.0705	.0583	.070	.0544	.071	.0558	.069	.071	.070	.069	.068	.070	.072
		.056	.069	.051		.0536			.0695	.0688		.071	.071
AR	AS	AT	AU	AV	AW	AX	BP	BQ	BR	BS	BT	BU	BY
.089	.089	.088	.089	.089	.090	.089	.089	.089	.089	.088	.088	.090	.089
.085	.0845	.0856	.084	.085	.085	.0843	.085	.085	.085	.0856	.0856	.085	.0845
.082	.079	.0833	.0815	.0805	.0807	.0807	.0814	.082	.0817	.0836	.0835	.080	.081
.0795	.075	.0809	.079	.0773	.078	.0775	.078	.079	.0785	.0817	.0813	.077	.0785
.0771	.0732	.0785	.0773	.0742	.0757	.075	.074	.075	.0757	.0799	.0792	.0745	.076
.0748	.0692	.0761	.0755	.0717	.0735	.073	.0715	.0725	.075	.0778	.0771	.072	.074
.073	.0665	.0738	.0737	.070	.0713	.071	.0695	.0705	.0741	.076	.0749	.0695	.072
.0712	.0635	.0714	.0717	.0675	.0693	.0692	.0673	.0685	.0739	.074	.0726	.0675	.070
.0696	.061	.069	.0698	.065	.0674	.0675	.065	.0662	.0728	.072	.0705	.0655	.066
.068	.0586	.0666	.068	.0625	.0655	.066	.0625	.064	.072	.0701	.0684	.0625	.068
.066	.056	.0643	.066	.060	.0637	.0645	.060	.0616	.071	.0683	.0663	.0602	.064
.064	.0533	.0619	.064	.059	.0618	.063	.058	.0594	.070	.0664	.064	.058	.062
	.051			.058	.060	.0615	.056	.057	.069			.056	.060

090 JET NEEDLES

BW	BX	BX1	BY	BZ			CS2	CT	CU	CW	CX	CY	CZ
-089	-089	-089	-088	-089			-089	-089	-089	-089	-089	-089	-089
-0855	-085	-085	-084	-084	-0843		-085	-085	-085	-085	-085	-085	-085
-0818	-0805	-0827	-0805	-081			-081	-081	-0825	-081	-081	-080	-0827
-079	-077	-081	-0775	-0752			-077	-077	-080	-079	-079	-076	-0806
-0765	-075	-0792	-0745	-0719			-073	-0738	-0775	-078	-0788	-0738	-0785
-0742	-0735	-0777	-0725	-0686			-069	-0706	-0735	-077	-078	-0715	-0745
-0718	-072	-076	-0709	-0653			-065	-0675	-0715	-0763	-0771	-0695	-0727
-0693	-0705	-075	-069	-0622			-0615	-0643	-070	-0754	-0763	-068	-071
-067	-0687	-074	-067	-059			-058	-061	-0683	-0745	-0755	-067	-0693
-0645	-067	-073	-0653	-056			-0546	-058	-0665	-0736	-0748	-066	-0675
-062	-0655	-072	-0635	-053			-051	-0547	-0647	-0727	-074	-0655	-0657
-0594	-064	-071	-062	-050			-0475	-0515	-0630	-0718	-073	-065	-064
-057			-060	-047			-044	-0485	-0650			-0645	-0625
C	CA	CB	CC	CD	CE	CF	D1	D2	D3	D4	D6	D7	D8
-089	-089	-089	-089	-089	-089	-089	-089	-089	-089	-089	-089	-089	-089
-0845	-0855	-085	-085	-085	-085	-085	-085	-085	-085	-0855	-0855	-0855	-085
-081	-084	-0805	-081	-0815	-082	-083	-082	-0815	-083	-0825	-0825	-0817	-0817
-077	-0825	-077	-078	-0775	-0795	-0805	-0802	-0800	-081	-0805	-0805	-0795	-0785
-0742	-081	-0745	-075	-0735	-0777	-0787	-0793	-0795	-080	-079	-0793	-0785	-0767
-071	-0807	-0725	-070	-076	-076	-0767	-0785	-0790	-0794	-078	-0785	-0778	-076
-0683	-0803	-071	-0698	-069	-0745	-0747	-0776	-0785	-0785	-0767	-0776	-077	-075
-066	-0803	-0695	-067	-0678	-0735	-0727	-077	-0780	-0778	-0756	-077	-0765	-074
-0635	-0803	-068	-064	-0666	-072	-0707	-0764	-0775	-0772	-0745	-0764	-0759	-073
-0613	-0803	-0665	-061	-0654	-071	-0687	-0759	-0770	-0764	-0733	-0759	-0752	-072
-0594	-0803	-065	-058	-0640	-0695	-0667	-0752	-0765	-0757	-0721	-0752	-0747	-071
-0575	-0803	-0635	-055	-063	-0682	-0647	-0748	-0760	-075	-071	-0748	-074	-070
-056	-0803	-062	-052	-062	-067								
CG	CH	CJ	CK	CL	CM	CN	D9	DA	DB	DC	DD	DE	DH
-090	-090	-090	-090	-090	-088	-089	-089	-089	-089	-089	-089	-089	-089
-084	-084	-084	-084	-084	-084	-085	-0852	-084	-085	-084	-085	-0855	-085
-081	-0803	-0815	-081	-080	-0805	-0812	-0825	-082	-082	-082	-0835	-0825	-0822
-079	-0782	-0795	-079	-0775	-0775	-078	-0806	-080	-080	-0805	-0817	-0802	-080
-0765	-0767	-0775	-0775	-076	-074	-075	-0791	-0788	-078	-0796	-0798	-0772	-0775
-075	-076	-0761	-077	-075	-0718	-072	-0778	-0784	-0753	-0794	-0782	-0745	-074
-0735	-0756	-0747	-0766	-0746	-070	-069	-0764	-0780	-0717	-0792	-0767	-0734	-072
-0722	-0752	-0734	-0762	-0742	-0685	-0665	-075	-0776	-0674	-0790	-0752	-0729	-071
-0707	-0747	-072	-0757	-0737	-0668	-064	-0736	-0773	-062	-0787	-0740	-0723	-070
-0693	-0743	-0705	-0753	-0733	-0652	-062	-0723	-0769	-0657	-0785	-0730	-0717	-069
-0678	-0738	-0691	-0749	-0728	-0635	-060	-071	-0765	-0493	-0783	-0720	-0712	-068
-0664	-0723	-0677	-0745	-0724	-062	-058	-0696	-0761	-043	-0780	-0710	-0707	-067
-065	-073	-0644	-074	-072	-060	-056							-066
CO	CP	CP4	CQ	CR	CS	CS1	DJ	DK	DL	DM	DN	DP	DQ
-089	-089	-088	-088	-088	-089	-089	-089	-089	-089	-089	-0805	-089	-089
-085	-085	-0852	-0852	-0852	-085	-085	-085	-085	-085	-084	-085	-085	-085
-081	-0813	-0825	-0825	-083	-0822	-081	-0822	-0817	-082	-081	-082	-081	-0815
-0787	-0793	-079	-0798	-0805	-0791	-077	-0795	-0787	-0795	-0791	-080	-0777	-0785
-0765	-0775	-0757	-0768	-078	-0765	-073	-0765	-0755	-077	-0780	-0782	-075	-076
-0747	-0757	-0725	-0737	-0754	-0725	-0692	-073	-072	-0745	-0775	-077	-0735	-073
-073	-074	-069	-0706	-0725	-0706	-066	-071	-070	-0715	-0770	-076	-0723	-071
-0725	-0735	-0655	-0676	-0697	-069	-063	-070	-069	-070	-0765	-075	-0715	-070
-072	-073	-062	-0646	-067	-0672	-060	-069	-068	-0685	-0760	-074	-071	-069
-0717	-0725	-0585	-0613	-064	-0655	-057	-068	-067	-067	-0755	-0728	-0703	-068
-0714	-072	-0545	-0585	-0613	-0638	-054	-067	-066	-0655	-0750	-0717	-0698	-067
-071	-0715	-051	-0555	-0585	-062	-051	-066	-065	-064	-0745	-0705	-069	-066
		-047	-0525	-0556	-0605	-048	-065	-064	-0625			-0688	-068

.090 JET NEEDLES

DR	DS	DT	DU	DV	DW	DY	EP	EQ	ER	ES	ET	EU	EV
.088	.089	.088	.089	.089	.089	.089	.089	.089	.089	.089	.088	.089	.090
.085	.085	.084	.085	.084	.085	.085	.085	.085	.085	.085	.086	.085	.0855
.080	.0805	.081	.081	.0822	.0815	.079	.0835	.0817	.0833	.0818	.0845	.0825	.0815
.0768	.0776	.078	.0775	.081	.0795	.0765	.0815	.0785	.081	.079	.0825	.0805	.078
.0735	.0759	.076	.0755	.0792	.0780	.074	.0795	.076	.0777	.077	.0893	.0785	.075
.0705	.074	.074	.074	.0781	.0765	.0715	.0775	.0746	.074	.0755	.0781	.077	.0725
.0675	.0725	.0723	.073	.078	.0752	.069	.0755	.0732	.0725	.0748	.0773	.0755	.0705
.065	.071	.0712	.072	.078	.074	.0665	.075	.072	.0712	.074	.077	.0745	.069
.0635	.0695	.0709	.071	.078	.0728	.0643	.075	.071	.0706	.073	.077	.074	.068
.0627	.068	.0705	.070	.078	.0714	.062	.075	.070	.0706	.073	.077	.074	.067
.0618	.067	.0703	.069	.078	.070	.061	.075	.069	.0706	.073	.077	.074	.066
.0608	.066	.0701	.068	.078	.0686	.060	.075	.068		.073			.065
.060		.070				.059							
DZ	E1	E2	E3	E3 1/2	E4	EA	EW	EX	EX 1/2	EY	EZ		
.089	.088	.089	.088	.088	.088	.089	.089	.088	.088	.088	.088		
.085	.0845	.085	.0862	.0845	.084	.085	.085	.0862	.0865	.0856	.0865		
.0827	.081	.0826	.082	.0817	.080	.081	.0825	.0835	.084	.0835	.0838		
.0795	.0775	.0788	.0803	.079	.078	.078	.081	.081	.0816	.0812	.0798		
.077	.075	.0763	.0775	.076	.076	.075	.079	.0785	.0794	.0789	.0775		
.0745	.0725	.0736	.0747	.073	.0739	.072	.0775	.076	.077	.0741	.0751		
.0715	.070	.0711	.072	.078	.0718	.0695	.0755	.0735	.0745	.0716	.0737		
.070	.0675	.0685	.0693	.0675	.0695	.067	.0745	.071	.072	.0706	.0726		
.0685	.066	.066	.0665	.0646	.0673	.0645	.074	.0685	.0698	.0704	.0716		
.067	.0626	.064	.0638	.0626	.0651	.062	.074	.066	.0675	.0701	.0706		
.0655	.0605	.062	.062	.0605	.063	.0595	.074	.0635	.065	.0698	.0696		
.064	.059	.060	.060	.059	.061	.057		.061	.0627				
.0625	.057	.058	.0582	.057	.059	.0545		.058	.0602				
EB	EC	ED	EE	EF	EG	EH	FA	FB	FC	FD	FE	FF	FG
.089	.089	.089	.089	.089	.088	.089	.089	.089	.090	.089	.089	.089	.089
.0855	.085	.085	.085	.085	.085	.085	.085	.085	.0865	.0865	.085	.0856	.085
.0835	.081	.0825	.080	.082	.080	.082	.081	.0806	.083	.084	.081	.0822	.0795
.0815	.0775	.0805	.0777	.0795	.0768	.0805	.077	.0767	.0795	.0805	.0775	.079	.075
.0795	.0740	.0785	.075	.077	.074	.0788	.072	.0729	.076	.078	.074	.0757	.071
.0777	.0705	.076	.0735	.074	.071	.0775	.067	.070	.073	.076	.071	.0722	.0678
.0762	.0675	.074	.072	.072	.0685	.077	.063	.0687	.071	.075	.0695	.0700	.065
.075	.0645	.072	.0715	.071	.0665	.077	.060	.0676	.070	.074	.0686	.0672	.0625
.074	.0625	.070	.0709	.070	.065	.077	.0585	.0667	.069	.073	.0678	.0651	.060
.073	.0605	.068	.0703	.069	.0637	.077	.0576	.0658	.068	.072	.0671	.0639	.068
.072	.0585	.066	.0696	.068	.062	.077	.0567	.065	.067	.071	.0664	.0622	.056
.071	.0570	.064	.069	.067	.061	.077	.056	.0643	.066		.0657		.054
	.0555	.062		.066	.060	.077	.055	.0635	.065		.065		.052
EI	EJ	EK	EL	EM	EN	EO	FI	FI	FJ	FK	FL	FM	FN
.089	.089	.089	.087	.089	.089	.088	.089	.089	.090	.089	.089	.090	.085
.085	.085	.085	.085	.085	.085	.085	.085	.085	.085	.085	.085	.083	.081
.081	.0805	.082	.080	.081	.0813	.0806	.082	.0825	.081	.083	.079	.0796	.081
.0775	.076	.081	.0775	.078	.0778	.0773	.080	.079	.0775	.0812	.0765	.0772	.0775
.073	.0715	.0792	.0747	.0763	.074	.0746	.079	.076	.076	.0796	.074	.075	.0735
.069	.068	.0777	.072	.0747	.0706	.072	.078	.073	.0745	.0784	.0715	.0727	.069
.066	.065	.0762	.070	.073	.068	.0697	.077	.0705	.0725	.0772	.069	.0703	.066
.0635	.0625	.075	.068	.0725	.0657	.0677	.076	.0693	.071	.076	.0665	.068	.063
.0618	.0605	.073	.066	.072	.0643	.0668	.075	.0682	.070	.0748	.065	.0657	.061
.060	.059	.075	.064	.0715	.0632	.0659	.074	.067	.068	.0736	.065	.0635	.058
.059	.058	.075	.062	.071	.062	.065	.073	.0656	.0665	.0724	.065	.0612	.055
.058	.057	.075	.060	.0705	.061	.064	.072	.064	.065		.0712		.060
.057	.056		.058		.060	.063		.063					

.090 JET NEEDLES

FO	FP	FQ	FR	FS	FT	FU	GN	GO	GP	GR	GS	GT	GU
.089	.0898	.0890	.089	.089	.089	.089	.089	.089	.089	.089	.089	.089	.089
.089	.0855	.0850	.085	.085	.085	.085	.0855	.086	.085	.085	.085	.085	.0855
.0818	.0826	.0820	.081	.0817	.082	.082	.0835	.0845	.080	.082	.0815	.082	.083
.0785	.0799	.0795	.078	.081	.0795	.080	.081	.0825	.076	.079	.0785	.0795	.0808
.076	.0778	.0774	.075	.0785	.0772	.078	.078	.0792	.075	.077	.0755	.077	.0775
.0745	.0762	.0758	.0728	.076	.0753	.0765	.0755	.0777	.0725	.075	.0725	.0745	.0745
.0751	.0754	.0745	.0705	.075	.0738	.075	.0725	.0765	.0696	.075	.070	.071	.0705
.0729	.0750	.0735	.0685	.074	.0728	.074	.070	.0755	.0666	.071	.0675	.0675	.067
.0727	.0743	.0725	.0665	.073	.0724	.0755	.0675	.0750	.0636	.069	.0650	.0640	.0635
.0725	.0755	.0715	.0642	.072	.072	.0728	.0650	.0745	.0606	.067	.0625	.0605	.060
.0723	.0728	.0705	.0622	.071	.072	.0724	.0625	.0740	.0577	.065	.060	.0570	.0565
.0721	.0720	.0695	.060	.070	.072	.0714	.060	.0755	.055	.065	.0575	.0555	.053
							.0575	.0730	.052	.061	.055		
FV	FW	FX	FY	FZ			GV	GW	GX	GY	GZ		
.089	.089	.089	.090	.089			.089	.089	.089	.089	.089		
.085	.085	.0855	.089	.085			.0855	.085	.0855	.0855	.0855		
.083	.081	.0827	.081	.0813			.0836	.083	.0835	.0832	.0835		
.080	.0775	.080	.0775	.0789			.083	.080	.0815	.0812	.0811		
.0775	.075	.0775	.075	.077			.0804	.0772	.0795	.079	.0788		
.0745	.0725	.075	.0735	.0754			.080	.076	.0775	.077	.0765		
.0715	.070	.0715	.072	.0748			.0796	.0745	.0755	.0753	.0742		
.0686	.0675	.068	.071	.074			.0793	.073	.0735	.074	.072		
.0658	.0665	.0655	.070	.0755			.0793	.0715	.072	.073	.0698		
.0647	.0665	.0637	.068	.075			.0793	.070	.070	.072	.0676		
.0636	.0665	.060	.066	.0725			.0795	.0685	.068	.071	.0655		
.0625	.0665	.059	.064	.072			.0795	.067	.066	.070	.0651		
.0614	.0665	.058	.062				.0793	.066	.064	.069	.061		
G1	GA	GB	GC	GD	GE	GE/R	H1	H2	H4	H4	HA	HB	HC
.0875	.089	.089	.089	.089	.089	.089	.088	.088	.089	.089	.089	.089	.089
.0835	.085	.085	.085	.085	.0845	.085	.085	.085	.085	.0855	.085	.085	.0855
.081	.0795	.082	.085	.0833	.083	.0825	.082	.082	.081	.082	.0825	.0825	.0822
.0785	.077	.0795	.080	.081	.0795	.0795	.0792	.0792	.0778	.080	.0805	.0805	.0805
.0765	.074	.0771	.0775	.079	.0766	.076	.0762	.0762	.076	.078	.0785	.0785	.0785
.0745	.0715	.0748	.0740	.0746	.0759	.0725	.0735	.0735	.0741	.076	.077	.0776	.077
.0725	.069	.075	.0705	.0705	.0712	.069	.0707	.0707	.072	.074	.0756	.0764	.0755
.0705	.067	.0712	.0665	.0745	.0686	.064	.0686	.0686	.0702	.072	.074	.0752	.0751
.069	.065	.0696	.0630	.0758	.0656	.064	.0665	.0661	.0685	.070	.0727	.0743	.0747
.0674	.0632	.0685	.0605	.0758	.0645	.062	.0644	.0658	.0665	.068	.0741	.0732	.0745
.066	.0615	.068	.0590	.0738	.0627	.0615	.0622	.0615	.064	.066	.0698	.072	.0729
.0642	.0597	.067	.0575	.0758	.0627	.061	.0601	.0592	.062	.064	.068	.071	.0755
	.058		.0560		.0627	.0605	.058	.057			.067	.070	
GF	GG	GH	GI	GJ	GL	GM	HD	HE	HF	HG	HV2	HV3	HV4
.089	.089	.089	.089	.089	.089	.089	.089	.090	.090	.089	.089	.089	.089
.085	.087	.0845	.085	.084	.084	.084	.0855	.0845	.0845	.0845	.084	.084	.084
.0795	.0845	.082	.0825	.0817	.082	.0842	.0825	.0817	.082	.0823	.080	.080	.080
.077	.0825	.0786	.079	.0792	.0795	.0817	.081	.080	.0805	.0802	.0778	.078	.0782
.0745	.0808	.0793	.075	.0770	.0772	.0782	.0795	.0787	.0797	.0782	.0756	.076	.0764
.073	.079	.0695	.0715	.0745	.075	.0770	.078	.078	.079	.0755	.0754	.074	.0746
.072	.078	.0655	.069	.0717	.0727	.0758	.0766	.0776	.0787	.0737	.0712	.072	.0728
.0715	.077	.0586	.067	.0696	.0706	.0750	.0762	.0772	.0784	.072	.069	.070	.071
.071	.0758	.0570	.0663	.0675	.0685	.0745	.0762	.0769	.078	.070	.0666	.068	.0692
.0703	.0745	.0565	.0665	.0654	.0644	.0740	.0754	.0766	.0776	.068	.0646	.066	.0674
.0696	.0732	.0565	.0665	.0632	.0642	.0755	.0751	.0763	.0774	.066	.0626	.064	.0636
.069	.071	.0565	.0665	.0611	.0621	.0750	.0748	.0759	.077	.064	.0602	.062	.0638
			.059	.060				.0755	.0766	.063	.058	.060	.062

.090 JET NEEDLES

JM						1	2	3	4	5	6	7
.089						.089	.089	.089	.089	.089	.089	.089
.085						.085	.085	.085	.085	.085	.085	.085
.081						.0 14	.0814	.0814	.0814	.0814	.0814	.0814
.078						.0785	.0785	.0785	.0785	.0785	.0785	.0785
.0752						.077	.0767	.0765	.0761	.0758	.0755	.0755
.0729						.0755	.0749	.0744	.0737	.0733	.0725	.072
.0702						.074	.0732	.0723	.0714	.0705	.0696	.0686
.068						.0725	.0714	.0703	.0692	.068	.0666	.065
.0653						.071	.0696	.0685	.0668	.0653	.0636	.062
.0627						.0695	.0678	.0661	.0645	.0627	.0606	.0587
.060						.068	.066	.064	.062	.060	.0577	.0553
.059						.067	.065	.063	.061	.059	.055	.052
.058						.066	.064	.062	.060	.058	.052	.049
L						20	21	24	24A	24B	41	42
.089	.L11'	L12	LS	LS1		.089	.089	.088	.088	.088	.089	.089
.085	.084	.085	.085	.085		.0855	.0855	.0845	.0845	.0845	.085	.085
.081	.0801	.081	.080	.080		.0822	.0827	.0815	.0815	.0815	.0805	.081
.079	.0772	.078	.077	.0765		.0792	.080	.0785	.0785	.0795	.0775	.078
.077	.0745	.0795	.0735	.075		.076	.0775	.0755	.076	.0775	.0745	.075
.075	.0722	.073	.0705	.071		.073	.075	.0725	.0738	.0755	.0725	.0734
.0735	.0702	.0702	.068	.0798		.0703	.0725	.0702	.0716	.0735	.0709	.0719
.072	.0675	.0675	.0658	.0678		.0677	.0697	.0682	.0698	.0715	.069	.070
.071	.065	.065	.0636	.066		.0647	.0671	.0667	.068	.0695	.067	.0685
.070	.0625	.0625	.0613	.064		.0624	.0646	.065	.066	.0675	.0635	.067
.069	.060	.060	.059	.062		.060	.0628	.0636	.064	.0655	.0635	.065
.068	.0575	.0575	.057	.060		.058	.0608	.0625	.062	.0655	.062	.0655
	.055	.055	.055	.058		.056	.059	.061	.060	.0615	.060	.062
M						69	80	81				
.089	.M1	M2	M5	M6	M7	M8	.089	.089	.089			
.0855	.085	.085	.085	.085	.085	.086	.085	.085	.085			
.0832	.0817	.0817	.0817	.0817	.0822	.0827	.0805	.080	.080			
.0808	.0796	.080	.0792	.0801	.0807	.0812	.0785	.078	.077			
.0785	.0777	.0785	.0776	.0786	.0792	.0797	.0765	.0758	.0742			
.0763	.0757	.0765	.076	.077	.0777	.0782	.075	.0735	.0719			
.0745	.0737	.0745	.0745	.0754	.0762	.0767	.074	.0705	.0699			
.0726	.0717	.0725	.0729	.0738	.0747	.0752	.075	.068	.068			
.0707	.0698	.0705	.0712	.0725	.0732	.0737	.072	.0653	.0655			
.0686	.0678	.0688	.0696	.0707	.0717	.0722	.071	.0627	.0627			
.0669	.0659	.0669	.068	.0691	.0702	.0707	.070	.060	.060			
.065	.064	.0665	.0666	.0676	.0687	.0692	.069	.059	.059			
							.058	.058				
M9						MA	MB	MME	MO	MOW	MW	
.089	.089	.089	.089	.089	.089	.089	.089					
.085	.085	.085	.085	.0855	.0855	.0855	.085					
.0897	.0817	.0815	.0813	.0835	.0837	.084	.0815					
.081	.0795	.079	.078	.0815	.082	.0825	.0795					
.0792	.078	.0767	.074	.080	.0808	.0811	.078					
.0777	.0763	.074	.0707	.07875	.0795	.0803	.077					
.0762	.075	.0715	.0673	.0775	.0785	.0792	.076					
.0747	.0735	.068	.0636	.07625	.077	.078	.075					
.0732	.072	.0653	.060	.075	.0758	.0768	.074					
.0717	.0705	.0627	.0563	.07575	.0745	.0757	.075					
.0702	.069	.060	.053	.0725	.0732	.0746	.072					
.0687	.0675	.059	.0495	.07125	.072	.0735	.071					
		.058	.046									

-090 JET NEEDLES

P4	P6	P61	P1					TB					
-088	-088	-088	-089					-089					
-0845	-0845	-0845	-085					-085					
-081	-081	-081	-082					-081					
-0785	-0775	-077	-0807					-078					
-0755	-0738	-0746	-0795					-075					
-073	-0703	-0715	-079					-073					
-070	-067	-0684	-0785					-071					
-0675	-0638	-0653	-078					-0698					
-0645	-0603	-062	-0775					-0678					
-06175	-057	-059	-077					-066					
-059	-054	-056	-0765					-064					
-0562	-0505	-053	-076					-062					
-0535	-0473	-050						-060					
QA	QW							V2	V3	V5			
-089	-089							-089	-089	-089			
-085	-085							-085	-085	-085			
-082	-0825							-082	-0826	-081			
-0796	-0802							-0795	-0804	-077			
-077	-0781							-0775	-0783	-0748			
-0745	-0755							-0756	-0764	-0725			
-072	-0731							-0738	-0746	-071			
-0695	-0708							-0718	-0726	-0695			
-0668	-0685							-0698	-0706	-068			
-0642	-066							-0678	-0686	-0665			
-0615	-0636							-0658	-0666	-065			
-059	-0613							-064	-0646	-0635			
-0565	-059												
R3	R3-2	R4	RLB	RLS	RO	RS		W3	WW	WX1			
-089	-088	-089	-089	-089	-089	-089		-088	-089	-089			
-085	-084	-085	-085	-085	-085	-085		-083	-085	-085			
-0805	-0805	-081	-081	-0804	-081	-0823		-0805	-0814	-082			
-0776	-0776	-077	-077	-074	-077	-081		-078	-0785	-0795			
-0759	-0759	-0732	-0732	-0725	-074	-0803		-0763	-0775	-0777			
-074	-074	-070	-0693	-0692	-071	-0795		-0745	-0765	-0765			
-0722	-0722	-0665	-066	-066	-0685	-0786		-073	-0755	-0755			
-0703	-0703	-063	-0626	-0626	-066	-078		-071	-0746	-0746			
-0687	-0687	-060	-0592	-0592	-0633	-0775		-0694	-0736	-0736			
-067	-067	-057	-056	-056	-0605	-077		-0677	-0718	-0728			
-065	-065	-054	-0526	-0526	-058	-0765		-066	-0718	-0718			
-0632	-0632	-051	-0495	-0495	-0558	-076		-065	-0709	-0709			
		-048	-046	-046	-053								
S	S4	S5	S4										
-089	-0895	-0895	-089										
-085	-0852	-0852	-085										
-0822	-082	-0815	-0805										
-0806	-079	-078	-077										
-079	-0765	-0753	-0743										
-0774	-0744	-073	-0715										
-0758	-0722	-0707	-069										
-074	-070	-0684	-0666										
-0724	-0677	-0663	-064										
-0708	-0656	-0639	-062										
-069	-0634	-0616	-059										
-0675	-0612	-0593	-0568										
	-059	-057	-0545										

100 JET NEEDLES

A9				GK				K				KA				KB				KC															
-098				-100				100	-099	-099	-099	-099	-099	-099	-099	-099	-099	-099	-099	-099	-099	-099													
-0946				-094				095	095	095	095	095	095	095	095	095	095	095	095	095	095	095													
-0913				-089				0905	092	092	092	092	092	092	092	092	092	092	092	092	092	092													
-088				-085				0865	0895	090	090	090	090	090	090	090	090	090	090	090	090	090													
-085				-081				083	0876	0886	0886	0886	0886	0886	0886	0886	0886	0886	0886	0886	0886	0886													
-0814				-078				080	0855	0872	0872	0872	0872	0872	0872	0872	0872	0872	0872	0872	0872	0872													
-0818				-075				-0777	0835	086	086	086	086	086	086	086	086	086	086	086	086	086													
-0802				-072				076	0814	085	085	085	085	085	085	085	085	085	085	085	085	085													
-0787				-069				074	0793	0845	0845	0845	0845	0845	0845	0845	0845	0845	0845	0845	0845	0845													
-077				-066				-0722	0784	084	084	084	084	084	084	084	084	084	084	084	084	084													
-0755				-063				0705	078	0835	0835	0835	0835	0835	0835	0835	0835	0835	0835	0835	0835	0835													
-074				-060				0665	078	082	082	082	082	082	082	082	082	082	082	082	082	082													
-0722				-057				-0667	078	0725	0725	0725	0725	0725	0725	0725	0725	0725	0725	0725	0725	0725													
-0706				-054				065	078	075	075	075	075	075	075	075	075	075	075	075	075	075													
BC				KD				KE				KF				KG				KH				KI				KK							
-099				-097	099	099	099	099	-099	-099	-098	-099	-099	-099	-099	-099	-099	-099	-099	-099	-099	-099													
-095				-095	095	095	095	095	-095	-0935	-094	-095	-095	-095	-095	-095	-095	-095	-095	-095	-095	-095													
-091				-0908	0917	091	091	0915	0883	090	0925	0883	090	0925	0883	090	0925	0883	090	0925	0883	090													
-088				-0883	090	089	0895	0863	0865	0893	0865	0893	0865	0893	0865	0893	0865	0893	0865	0893	0865	0893													
-085				-0856	0865	0875	0875	0843	083	086	086	086	086	086	086	086	086	086	086	086	086	086													
-0825				-083	087	0855	0855	0825	080	0828	080	0828	080	0828	080	0828	080	0828	080	0828	080	0828													
-0803				-0775	0848	0835	0841	0805	0777	0795	0795	0795	0795	0795	0795	0795	0795	0795	0795	0795	0795	0795													
-0785				-074	0838	082	0834	0785	076	0738	076	0738	076	0738	076	0738	076	0738	076	0738	076	0738													
-0765				-0705	083	081	0827	076	074	0615	074	0615	074	0615	074	0615	074	0615	074	0615	074	0615													
-075				-067	0822	080	0820	0725	0722	0517	0722	0517	0722	0517	0722	0517	0722	0517	0722	0517	0722	0517													
-073				-0635	0815	0795	0810	071	0705	042	0705	042	0705	042	0705	042	0705	042	0705	042	0705	042													
-072				-060	0808	079	0800	0685	0685	042	0685	042	0685	042	0685	042	0685	042	0685	042	0685	042													
-071				-0565	080	079	0790	066	0667	042	0667	042	0667	042	0667	042	0667	042	0667	042	0667	042													
-070				-053	0792	079	0780	065	065	042	065	042	065	042	065	042	065	042	065	042	065	042													
CI				CIW				CV				KT				KTA				KW				KWf				KW1				KWR			
-099	099	099		100	100	100	100	100	100	100	100	100	100	100	100	100	100	100	100	100	100	100													
095	0955	094		095	095	095	095	095	095	095	095	095	095	095	095	095	095	095	095	095	095	095													
0916	093	090		0905	0895	091	0915	0905	090	090	090	090	090	090	090	090	090	090	090	090	090	090													
0889	0905	0867		087	0865	0877	0885	0875	087	087	087	087	087	087	087	087	087	087	087	087	087	087													
0861	0875	084		0845	0825	084	0851	0845	084	084	084	084	084	084	084	084	084	084	084	084	084	084													
084	0856	0815		0822	0815	0805	082	0815	081	081	081	081	081	081	081	081	081	081	081	081	081	081													
0818	0836	0795		0802	0802	077	079	0788	076	076	076	076	076	076	076	076	076	076	076	076	076	076													
0796	0819	0775		079	0788	073	076	076	076	076	076	076	076	076	076	076	076	076	076	076	076	076													
0778	080	076		0775	0775	0695	0728	0728	0728	0728	0728	0728	0728	0728	0728	0728	0728	0728	0728	0728	0728	0728													
076	078	0745		076	076	0661	0695	0695	0695	0695	0695	0695	0695	0695	0695	0695	0695	0695	0695	0695	0695	0695													
074	076	0732		075	075	063	0663	0663	0663	0663	0663	0663	0663	0663	0663	0663	0663	0663	0663	0663	0663	0663													
073	0752	072		074	074	060	063	063	063	063	063	063	063	063	063	063	063	063	063	063	063	063													
072	0746	071		073	073	057	060	060	060	060	060	060	060	060	060	060	060	060	060	060	060	060													
071	074	070		072	072	054	057	057	057	057	057	057	057	057	057	057	057	057	057	057	057	057													
DF				DG				DX				LB1				LB2				LFN				LSA				MC							
100	100	099		096	095	094		0925	091	0885	093		0895	0895	085	0906		0885	0885	0885	0885	0885													
098	098	0958		087	086	0815		087	086	0815	0883		085	084	078	0863		0851	0851	0851	0851	0851													
096	096	0926		082	0804	0775		085	084	078	0863		085	084	078	0863		082	082	082	082	082													
091	0905	0888		0782	0772	0740		083	0825	075	0848		082	0815	0723	0839		079	079	079	079	079													
088	087	0859		075	074	0705		082	0815	0723	0839		081	0805	0695	0830		076	076	076	076	076													
085	0836	0830		0725	071	0670		081	0805	0695	0830		080	0795	0668	0821		0728	0728	0728	0728	0728													
082	0804	0775		070	0689	0635		079	0785	064	0812		078	0775	061	0804		064	064	064	064	064													
0802	0772	0740		067	0653	0565		078	0775	061	0804		077	0765	0585	0796		060	060	060	060	060													
075	074	0705		0655	0636	0530		077	0765	0585	0796		076	0755	0556	0788		0555	0555	0555	0555	0555													
0725	071	0670		064	062			076	0755	0556	0788							051	051	051	051	051													

100 JET NEEDLES

							SA	SB	SC	SD	SE	SF	SG
.100	.100	.100		.100	.100	.100	-.099	-.099	.100	.100	-.100	-.100	-.100
.095	.095	.095		.096	.096	.097	-.095	-.095	.095	.095	-.095	-.095	-.095
.090	.090	.090		.0917	.093	.094	-.0915	-.091	.0915	.0912	.0915	-.09125	-.0917
.0850	.0850	.0850		.0887	.0902	.0913	-.0885	.0875	-.0882	-.088	-.0903	-.0895	-.090
.0815	.0815	.0815		.0856	.0872	.0888	-.086	-.084	-.0865	-.0862	-.0888	-.08825	-.0887
.0777	.078	.078		.0825	.0843	.086	-.084	-.080	-.0845	-.0842	-.087	-.087	-.0878
.0738	.074	.0744		.0794	.0814	.0835	-.0815	-.076	-.0823	-.0822	-.0852	-.08575	-.0869
.070	.070	.0712		.0762	.0786	.0808	-.079	-.072	.080	.080	-.0845	-.085	-.0862
.0660	.067	.0685		.0731	.0757	.0782	-.0768	-.0695	.079	.079	.084	-.0845	-.0859
.0636	.064	.066		.070	.0727	.0755	-.0743	-.067	.078	.078	.084	-.084	-.0855
.0606	.062	.064		.067	.070	.073	-.072	-.064	-.077	.077	.084	-.084	-.0855
.0579	.060	.062		.064	-.067	.0702	-.070	-.062	.076	.076	-.084	-.084	-.0855
.0552	.057	.060		.061	-.064	-.0675	-.068	-.059	.075	.075	-.084	-.084	-.0855
.053	.055	.058		-.058	-.061	-.065	-.066	-.057	.074	.074	-.084	-.084	-.0855
RA	RB	RC	RD	RE	RF	RG	SH	SJ	SK	SL	SM	SN	SO
.100	.099	.099	-.099	-.099	-.100	-.100	-.099	-.099	-.099	-.099	-.099	-.099	-.100
.094	.095	.0946	.095	.095	.095	.095	.0952	-.095	.0954	-.095	-.095	-.095	-.096
.088	.0907	.090	.090	.092	.090	.0905	.0917	.092	.093	.092	.0915	-.0915	-.092
.083	.0866	.0855	.0865	-.089	.0863	-.087	-.0885	-.0895	.090	.089	.0895	-.0885	-.089
.0785	.0825	.081	-.0835	-.0856	-.0825	-.0836	-.0865	-.0875	-.0867	-.0867	-.0855	-.0865	-.086
.0753	.0784	.0765	.081	.0805	-.0788	.0802	-.0845	-.0855	.0833	-.0833	-.0825	-.0845	-.083
.0722	.074	.072	-.079	-.0753	.075	.0768	-.082	-.0835	-.080	-.080	-.0795	-.0835	-.0804
.069	.070	.0674	-.077	-.0712	.0712	.0732	-.0793	-.0815	-.077	-.077	-.0765	-.082	-.0778
.0658	.0657	.0627	.0757	-.0670	.0675	.070	-.077	-.0793	-.074	.074	-.0735	-.080	-.075
.0627	.0615	.0583	.0742	-.0628	-.0637	-.0665	-.0743	.077	.0714	-.0714	-.071	-.078	-.0743
.0595	.0575	.0537	.073	-.0587	.060	-.0630	-.0722	-.075	.0695	-.0695	-.069	-.0765	-.0737
.0564	.0532	.0492	.0715	-.0543	.057	-.060	-.070	-.073	-.0676	-.0676	-.067	-.075	-.073
.053	.049	.0446	.0703	-.0501	.054	-.057	-.068	-.071	-.065	-.065	-.065	-.074	-.0722
.050	.045	.040	-.069	-.0460	-.051	-.054	-.066	-.067		-.063	-.063	-.073	
RH	RI	RJ	RK	RL	RN	RP	SP	SQ	SR	SS	ST	SU	SY
.100	.099	.100	.100	.100	.099	.099	-.099	-.100	-.099	-.099	-.099	-.099	-.099
.095	.095	.095	.095	.095	.095	.095	-.095	-.095	-.095	-.0945	-.095	-.095	-.0955
.0915	.0912	.0910	.0915	.0920	.092	.0905	-.0915	-.0915	-.092	-.0905	-.0923	-.092	-.0923
.0878	.0881	.087	-.088	-.089	.089	-.087	-.0892	-.088	-.089	-.086	-.0895	-.0868	-.089
.0846	.0846	.0844	.0854	-.086	-.0859	.085	-.0871	-.0854	-.086	-.084	-.087	-.0834	-.0867
.0813	.0804	.0818	-.0830	-.0835	-.0808	.0832	-.0852	-.083	-.083	.080	-.0852	-.0802	-.0845
.078	.0763	.0792	-.0805	-.0810	-.076	.082	-.0834	-.0812	-.0804	-.0755	-.0831	-.0764	-.0818
.075	.0722	.0766	-.0800	.0785	-.0731	-.0815	-.0810	-.0794	-.0778	-.0715	-.0805	-.0728	-.079
.072	.067	.0740	.0756	.0760	-.0688	.0809	-.0786	.0775	-.075	-.0655	-.0787	-.069	-.0755
.069	.0605	.0714	.0732	-.0735	-.0651	.080	-.0762	-.0757	-.0743	-.059	-.077	-.0655	-.072
.066	.0567	.0688	-.0708	-.0710	-.0617	-.0794	-.0738	-.0728	-.0737	-.0535	-.0753	-.062	-.0685
.063	.0525	.0662	.0693	-.0685	-.0581	.0786	-.0714	-.0719	-.073	-.0485	-.0737	-.0586	-.0665
.060	.049	.0630	-.066	-.0660	-.0547	-.0778	-.069	.070	-.0722	.045	.071	-.0552	-.0635
.057		.0610	-.0635	-.0635	-.0510	-.077	-.0666	.068	-.0715	-.042	-.069	-.0518	-.064
RR	RU	RV					SW	SX	SY	SZ			
-.099	-.100	-.100					-.099	-.099	-.099	-.099			
.095	.095	.095					-.0955	.096	-.095	-.0945			
-.0922	-.089	-.089					.0925	.0902	-.091	-.0903			
-.0895	-.084	-.084					-.088	.0868	-.0875	-.0858			
-.086	-.081	-.081					-.086	.084	-.0855	-.0837			
-.0808	.0785	.0785					-.084	-.0888	-.0825	-.0798			
.076	.0756	.0755					-.082	-.0774	-.078	-.0753			
-.0721	-.0733	-.073					.0795	.0744	-.075	-.0707			
-.0688	.071	.070					.077	-.0713	-.069	-.0643			
-.0651	-.0688	.067					-.0745	-.0686	-.063	-.0570			
-.0617	-.066	.0645					-.072	-.0657	-.0575	-.0508			
-.0581	.0636	.0618					.0695	-.063	-.0525	-.0470			
-.0547	-.061	.059					-.067	-.060	-.049	-.0445			
-.051	-.059	-.056					-.0645	-.0572	-.046	-.0420			

100 JET NEEDLES

TA	TC	TD	TE	TF	TG	TH
-099	-099	-099	-099	-099	-099	-096
-095	-095	-095	-095	-096	-095	-092
-0915	-0915	-0925	-092	-0925	-0922	-0908
-0882	-089	-090	-0895	-089	-0895	-0893
-0867	-087	-0875	-087	-0855	-0878	-0878
-0852	-085	-0845	-0837	-082	-0862	-0863
-0831	-0832	-0803	-0805	-0782	-0847	-0848
-0805	-0825	-077	-076	-0748	-0837	-0825
-0787	-0815	-073	-0715	-0714	-0827	-074
-0770	-0805	-0678	-067	-068	-0818	-065
-0753	-0795	-0631	-0625	-0645	-0812	-055
-0737	-0785	-0585	-058	-061	-0806	-049
-0710	-0775	-0538	-0535	-0575	-0800	-044
-0690	-0765	-049	-049	-054	-0794	-040
TJ	TK	TL	TM	TN	TO	TP
-099	-099	-099	-099	-099	-099	-099
-095	-095	-095	-095	-0945	-095	-0955
-092	-092	-092	-092	-091	-092	-092
-0895	-090	-089	-0894	-087	-0893	-090
-0877	-0885	-086	-0867	-085	-0865	-0875
-086	-087	-0835	-0842	-082	-0845	-0856
-0845	-086	-081	-0814	-078	-083	-0836
-084	-0855	-0793	-0785	-073	-082	-0819
-083	-0845	-0776	-0775	-0665	-081	-080
-082	-0835	-0759	-077	-060	-080	-078
-081	-0825	-0746	-077	-0535	-079	-076
-080	-0815	-0733	-077	-050	-078	-0752
-079	-0805	-072	-077	-0475	-077	-0746
-078	-0795	-071	-077	-045	-076	-074
TR	TS	TT	TU	TV	TW	TX
-099	-099	-0989	-099	-099	-099	-099
-095	-095	-0941	-095	-095	-095	-095
-092	-0915	-0904	-091	-0925	-0925	-091
-089	-088	-0883	-088	-090	-0895	-0894
-0869	-0853	-0861	-085	-088	-087	-0867
-084	-0823	-0825	-081	-086	-0852	-0842
-0817	-0812	-0799	-081	-084	-0831	-0814
-0791	-0782	-078	-0793	-0825	-0805	-0785
-0765	-0742	-0766	-0776	-081	-0775	-078
-0738	-0710	-0748	-0759	-080	-075	-078
-071	-0675	-0733	-0746	-0795	-0722	-078
-0685	-061	-0721	-0733	-0785	-070	-078
-063	-055	-0715	-072	-0775	-068	-078
-062	-049		-071	-0765	-066	-078
TY	TZ		WO2	WO3	WO4	
-099	-099		-100	-100	-100	
-095	-095		-095	-095	-095	
-0918	-0915		-091	-091	-090	
-0887	-0893		-087	-08775	-086	
-086	-087		-0835	-0845	-082	
-0836	-0847		-081	-0822	-0794	
-0825	-0827		-0785	-080	-0768	
-0805	-0805		-074	-078	-074	
-0775	-0787		-0732	-0755	-0712	
-075	-077		-071	-0735	-069	
-0722	-0753		-0683	-0712	-066	
-070	-0737		-0657	-069	-0634	
-068	-071		-063	-067	-061	
-066	-069		-061	-065	-058	

ZB	ZC	ZD	ZE	ZF	ZG	ZH
-099	-099	-099	-099	-099	-099	-099
-095	-095	-095	-095	-095	-095	-095
-0915	-091	-090	-0895	-089	-089	-0915
-089	-088	-865	-0858	-085	-0845	-0893
-0865	-0855	-084	-083	-0821	-0815	-087
-084	-083	-0815	-0805	-0798	-079	-0847
-082	-081	-079	-0782	-0775	-0765	-082
-0795	-0785	-077	-076	-075	-074	-0795
-0775	-0765	-0745	-0732	-072	-071	-0775
-0755	-0745	-072	-0703	-0687	-0675	-0755
-0735	-0725	-069	-0673	-065	-063	-0735
-071	-0695	-065	-0629	-0608	-059	-0715
-067	-065	-0605	-0584	-0563	-054	-0695
-063	-0605	-056	-054	-052	-050	-0675
-059	-056	-0515	-0495	-0475	-045	

125 JET NEEDLES

NA	UA	UB	UC	UD	UE	UF
-124	-124	-124	-124	-124	-124	-124
-1205	-1205	-120	-1205	-1205	-1205	-1205
-1170	-1175	-1165	-118	-1178	-1155	-1163
-1144	-1146	-113	-1153	-1158	-1135	-113
-1125	-1117	-111	-1128	-114	-1112	-1106
-1108	-1074	-109	-1107	-1126	-109	-1073
-1090	-1023	-107	-1086	-1115	-107	-1035
-1078	-0974	-1055	-107	-1104	-105	-0997
-1063	-0931	-104	-1056	-1092	-103	-0960
-1065	-0890	-103	-1046	-108	-1015	-0926
-1065	-0849	-102	-104	-1069	-100	-089
-1065	-0808	-101	-1032	-1064	-099	-0854
-1065	-0767	-100	-1025	-1058	-098	-0819
-1065	-0726	-099	-1018	-1047	-0965	-0783
-1065	-0685	-098	-101	-1036	-095	-0748
-1065	-0644	-097	-1002	-1025	-0935	-0713

125 JET NEEDLES

UG	UH	UI	UJ	UK	UL	UM	VA UVA	VB UVB	VC UVC	VD UVD	VE UVE	VF UVF	VG UVG
-124	-124	-124	-124	-124	-124	-124							
-1205	-1205	-1205	-1205	-1205	-1205	-1205	-124	-124	-124	-124	-124	-124	-124
-116	-1165	-1172	-1165	-116	-1175	-1165	-1188	-1188	-1188	-1184	-1178	-1172	-1166
-112	-1135	-114	-1135	-113	-1140	-114	-1145	-1145	-1145	-1155	-1125	-1114	-1103
-1084	-1105	-1114	-1105	-1106	-1115	-1125	-111	-111	-111	-1096	-108	-1063	-1047
-1054	-1085	-1092	-108	-1073	-1090	-1104	-108	-108	-108	-106	-104	-102	-100
-1023	-1065	-107	-1055	-1035	-1076	-1086	-1061	-1056	-1052	-105	-1008	-985	-962
-099	-104	-105E	-103	-0997	-106	-107	-1044	-1054	-1025	-100	-975	-95	-925
-0954	-1015	-1032	-100	-0960	-1035	-1056	-1025	-101	-0997	-097	-0945	-0915	-887
-0923	-099	-1018	-097	-0927	-1006	-1046	-1006	-0986	-097	-094	-091	-088	-85
-0895	-0965	-1006	-094	-090	-098	-104	-0987	-0964	-0945	-091	-0877	-0845	-815
-086	-094	-0995	-091	-0875	-0956	-1032	-0968	-094	-0915	-088	-0846	-081	-775
-0845	-0915	-0985	-0875	-0860	-0937	-1025	-095	-0917	-0888	-0852	-0814	-0775	-757
-083	-089	-0975	-0845	-0845	-0917	-1018	-0952	-0895	-086	-0822	-078	-074	-70
-0815	-0865	-0965	-0815	-0850	-0897	-101	-0913	-0872	-0855	-079	-075	-0715	-0662
	-084	-0955	-080	-0815	-0877	-1002	-0895	-0848	-0805	-076	-0715	-067	-0625
							-0875	-0825	-0777	-0752	-0685	-0655	-0586
UN	UO	UP	UR	US	UT	UU	VH UVH	VI UVI	VJ UVJ	VK UVK	VL UVL	VM UVM	VN UVN
-124	-124	-124	-124	-124	-124	-124	-124	-124	-124	-124	-124	-124	-124
-1205	-1205	-1205	-1205	-1205	-1205	-1205	-116	-1154	-1146	-1134	-1122	-1122	-1122
-1165	-1155	-116	-116	-116	-1172	-1147	-109	-1077	-1065	-1046	-105	-103	-103
-113	-1135	-114	-1128	-1155	-1114	-114	-105	-1015	-0997	-0997	-0956	-0946	-0946
-110	-110	-1105	-1094	-1105	-1084	-112	-098	-096	-094	-092	-090	-088	-087
-107	-108	-1075	-106	-1092	-1054	-1095	-094	-0917	-0895	-0874	-085	-0827	-080
-104	-1055	-1045	-105	-1085	-1023	-107	-090	-0875	-085	-0825	-080	-0775	-0734
-1005	-103	-1025	-0997	-1068	-0990	-105	-086	-0853	-0805	-0778	-075	-0722	-067
-0985	-101	-101	-096	-1043	-0954	-1025	-082	-079	-076	-073	-070	-0668	-0604
-0965	-0985	-0995	-0927	-102	-0917	-100	-078	-0748	-0715	-0684	-065	-0615	-055
-0945	-0965	-0985	-090	-1006	-088	-099	-074	-0715	-067	-0635	-060	-0565	-0494
-0915	-094	-0975	-0875	-0995	-0858	-098	-070	-0662	-0625	-0588	-055	-051	-044
-0885	-095	-096	-0860	-0985	-0856	-097	-066	-062	-058	-054	-050	-0457	-039
	-0915	-0945	-0845	-0975	-0815	-096	-062	-0577	-0555	-0495	-045	-0405	-054
-0855	-090	-095	-083	-0965	-079	-0945	-058	-0535	-049	-0445	-040	-055	-0295
-0850	-089	-0915	-0815	-0955	-0768	-095	-054	-0492	-0445	-0396	-055	-030	-025
-0805													
UV	UW	UX	UY	UZ			VO UVO	VP UVP		VR UVR	VT UVT		ZA
-124	-124	-124	-124	-124			-124	-124		-124	-125		-099
-1205	-1205	-1205	-1205	-1205			-121	-121		-119	-121		-095
-1182	-1175	-1165	-1174	-1172			-117	-117		-1145	-116		-0905
-1160	-1146	-114	-1145	-1135			-115	-113		-1108	-1115		-0875
-1155	-1117	-112	-1128	-1115			-110	-110		-1073	-107		-0847
-1112	-1074	-1095	-1107	-1095			-1075	-107		-1038	-104		-0822
-1095	-1025	-107	-1086	-1084			-105	-104		-1004	-099		-080
-108	-0974	-105	-107	-1066			-1022	-100		-097	-095		-0778
-1065	-092	-1025	-1056	-1048			-0995	-0965		-0925	-091		-0758
-1055	-0865	-100	-1046	-103			-097	-093		-088	-087		-0737
-1047	-081	-099	-104	-102			-0935	-089		-0835	-084		-071
-1042	-0755	-098	-1032	-101			-0895	-0855		-079	-081		-0675
-1036	-070	-0955	-1025	-100			-0855	-082		-076	-0775		-063
-1029	-064	-0951	-1018	-099			-082	-0782		-073	-0745		-0585
-1029	-058	-091	-101	-098			-078	-0745		-070	-072		-054
-1029	-052	-089	-1002	-097			-074	-0707		-067	-069		

NOTE.—V Series, $\frac{1}{32}$ " U V Series, $\frac{1}{16}$ " shank

·125 JET NEEDLES

25 U25	35 U35	45 U45	50 U50	59 U59	60 U60	78 U78
·124	·124	·124	·124	·124	·124	·125
·123	·123	·123	·117	·116	·117	·119
·116	·116	·116	·111	·111	·111	·113
·109	·109	·109	·104	·106	·104	·1085
·100	·100	·101	·099	·101	·099	·104
·092	·092	·094	·092	·096	·094	·0995
·084	·085	·089	·086	·091	·089	·095
·076	·078	·082	·080	·087	·084	·0905
·067	·071	·076	·073	·083	·0795	·086
·059	·064	·070	·068	·079	·075	·081
·051	·057	·064	·062	·075	·070	·077
·042	·050	·057	·056	·071	·065	·072
·034	·042	·051	·050	·067	·060	·068
·025	·035	·045	·044	·063	·055	·063
			·038	·059	·050	·059
74 U74	75 U75	76 U76	78 U78	79 U79		01 U01
·124	·125	·124	·124	·124		·124
·117	·119	·117	·117	·1178		·123
·112	·113	·112	·112	·1147		·1175
·108	·1087	·109	·109	·1115		·1115
·104	·105	·1055	·107	·1084		·1065
·100	·1101	·1022	·104	·1053		·1015
·097	·097	·099	·101	·1022		·097
·094	·093	·0958	·0978	·0991		·092
·090	·089	·0924	·094	·096		·087
·087	·085	·0892	·091	·093		·087
·084	·081	·086	·088	·090		·0775
·081	·077	·083	·086	·087		·0725
·078	·073	·080	·082	·084		·0675
·076	·069	·078	·080	·087		·063
·074	·065	·076	·078	·080		·058
·072		·074	·076	·078		

NOTE: Numbered Series, .156" shank. 'U' Series, .125" shank

ANGLO AMERICAN

Electrical & Carburettor Services Ltd.
134 Norwood Road,
London, S.E.24

Tel: 01-674 4477

REPLACEMENT S.U. CONVERSIONS

Replacement downdraught carburettors

Prices from 5 gns.

ZENITH — SOLEX — CARTER — WEBER — STROMBERG

FOR
FURTHER
DETAILS
FILL IN THIS
FORM AND
POST TO:

NAME

ADDRESS

MAKE OF CAR, MODEL & YEAR

TYPE OF CARB FITTED

WESTERN SERVICES (BRISTOL) LTD
Shaftsbury Buildings · Kingsland Road

Tel: 0272 551558
St. Philips · Bristol 2

The simplest thing in the world to lower the cost of motoring

The Colortune Diagnostic
plug makes it easy to correct
faults and achieve optimum
performance on any car.

A recent survey showed it could
save 15% on fuel costs.

I would like to read what Motor,
Engineering, Motor Cycle and Ford
write about Colortune.

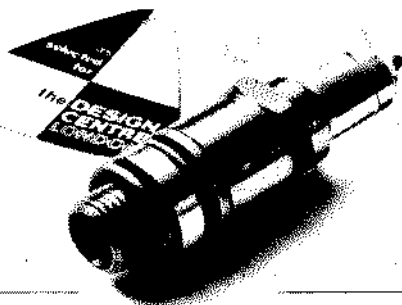

Name

Address

Colortune

Colortune, 66 Royal Mint Street, London, E.1. Tel: 01-480 7561

S.U.1