

BODY

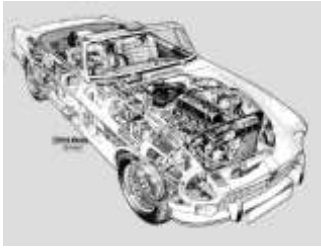

The MGB's body was a major change in engineering direction for MG. The decision was made to use the monocoque construction method that they had used on the ZA Magnette sedan. The body was made of steel, with aluminium bonnet (until 1969).

The bones of the vehicle comprised of two side members (front) which ran back to a cross member behind the gearbox. The front of these side members were held by a removable front suspension cross member (which was bolted on). The rear side members, which curved over the rear axle, were linked with the double-sectioned sills (sill closing and side member) (see photo below). All this was reinforced by: floor pans, transmission tunnel, boot floor, bulkhead, dashboard, door posts and a variety of panels, all adding strength to the construction. Apart from the front wings (which were bolted on), everything else was spot-welded.



Photo showing monocoque construction (photo: mg.net)

There were very few changes (body-wise) to the MGB over the ten years of production in Australia.

Grilles

The grille of the early YGHN3 vehicles (up to and including the 18GA engine) had separate stainless steel slats riveted on to the grille frame.



Early grille – slats individually riveted (photo: mymgb.net)

Thereafter, from vehicle YGHN3/1930, the grille, including the slats, were made from one-piece pressed aluminium. (p/no. ARH 218). The fittings didn't alter.



Later grille (Mk I & II). Grille made of pressed aluminium.

With the introduction of the Mk II (facelift), the grille changed its appearance; recessed black vertical slats with a 'D'-shaped chrome insert (laying on its back). In the centre was a new MG logo



Mk II (facelift) grille

Fuel tanks

1965 saw modification to the boot floor to allow for the change of fuel tanks, from the 10 gallon tank (which was attached by straps), to the 12.7 gallon tank which was bolted to the boot floor. This change started with YGHN3/2246 and from YGHN3/2258 onwards.

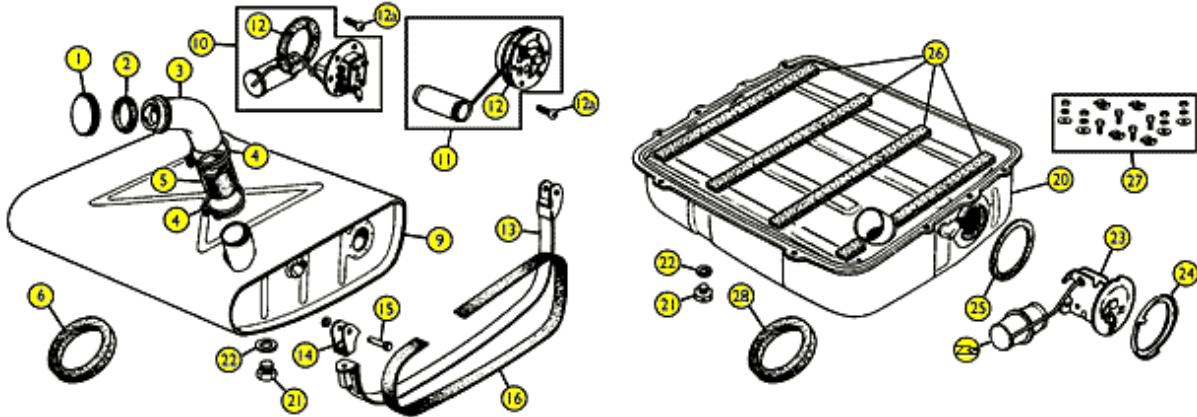

Both tanks – 10 gal and 12.7 gal (on right)

Doors

Around 1965, the doors were also slightly modified to accommodate the change from 'pull-out' handles to the 'push-button'.



Early 'pull' handle c/f later 'push button'

The pull handle (p/no AHH6661 & AHH6662) was fitted to cars YGHN3 501 - 2268.

From YGHN3 2269, the push-button (p/no AHH7452 [not handed]) was fitted. There is however, a subsequent listing of a variant [also not handed] (p/no AHH8885) but no changeover date listed (Leacy list it as '1965 -'1980).

An interesting door issue occurred during the assembly of the first Mk II vehicles at Zetland. New jigs had been made and in an attempt to make the door fitting even more presentable, tolerances were reduced. This appeared to work just fine UNTIL the car was lowered under its own weight. The first 12 or so car's doors would not open! These cars had to be reworked (and jigs altered) and sent back to the Paint Shop. Some of these cars could have up to three extra coats of paint, causing some cracking and chipping issues later in their lives.

Rear bumper infills

On the early Mk I cars (YGHN3/501 – YGHN3/100), the infills between the rear bumper and the body (next to tail lights) were painted body colour.



Early, large, painted bumper infill

Thereafter (YGHN3/1001) they were smaller and polished aluminium.



Later smaller bumper infill (polished alloy)

Petrol cap

Petrol caps were the non-lockable, vented type. Plain stainless steel with grooves around the circumference



Additional changes that occurred

- Late 1967 the laminated windscreen (p/no. AHH 7121) was replaced with a new, high impact windscreen (p/no. AHH 8226)
- From car YGHN3/5039, the paint drain holes in the floor pan were sealed, to prevent the ingress of water.
- Due to the problems experienced (mentioned elsewhere), it was decided, at car YGHN3/5168, to use boot, door and bonnet 'gap gauges', set at the upper limits, to counteract the gaps closing in the final assembly.
- Progressive corrections/improvements were occurring all the time. Refinements to the body finish below the rear bumper were carried out from car YGHN3/5455 onwards, addressing minor concerns in production.

Changes occurring with the introduction of the Mk II

Most of the changes occurred with the introduction of the Mk II series (YGHN 4 onwards); A wider gearbox tunnel was introduced to accommodate the new automatic gearbox configuration .



Figure 1 Early 3-sync tunnel c/f wider 4-sync tunnel. Compare the ribs on both sides to see the difference

Reversing lights

Pressed cut-outs for the inclusion of reversing lights (from car YGHN3/4487)(circa June 1967)



This photo shows the pressings made for the reverse lights (photo: A Helgeson)

Front parking/indicator lights

Also, from car YGHN3/4487, the slight inward movement of the parking/indicator cut-out on the front fender assembly. NB: *“While not recorded in contemporary publications at the time, this was done in the UK because of legislation introduced in some European markets that the parking (side) lights centre point should line up with the centre point of the headlights. While the modified front mudguards were introduced for the Australian assembled MGB as these panels came on line, the indicator/parking light units remained reversed compared to the UK built product, till the introduction of the YGHN9 models with their recessed grilles.”* (Tom Aczel, 2013)



There is no better way to show this change. This car has mismatched guards. Look at the distance the park lights are from the grille.

Bonnet material change

British Leyland, in Service Liaison Letter No 68 (2/9/71) notified that...

“To overcome paint finishing problems, the bonnet panel assembly is now manufactured from steel instead of aluminium, at the following commencing car serial numbers:

Overdrive: YHN9 – 1234 Automatic: YHN10 – 543”

Windscreen

As most people who have tried it would attest, one of the most frustrating jobs on an MGB is the fitting of a new windscreen to the car. The staff at the factory were not immune to this problem and many windscreens were cracked during installation, causing delays for that vehicle.

Enfield v Zetland

For those interested in ensuring their vehicles are true to the original specifications, a note about the screws holding the front guards on. At Zetland, (so we are talking about Mk II cars), the whole body was roto-dipped then sprayed. At Enfield, the guards were sprayed separately. Therefore, Zetland nuts would be painted the colour of the car and Enfield nuts just plated.